

# FORD AOD (FIOD) AOD-E (ELECTRONIC)

# 4R70W/4R75W 4R70E/4R75E

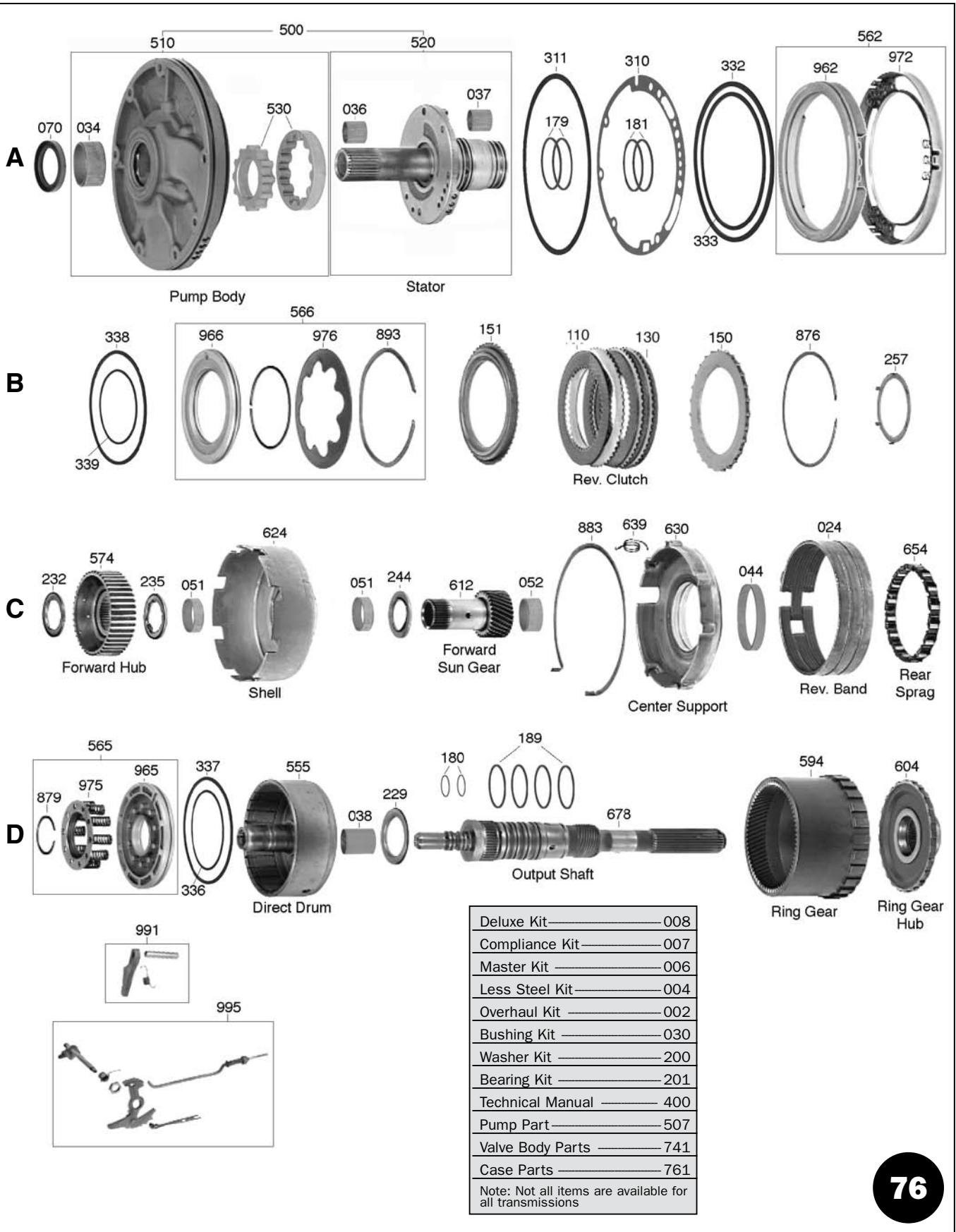

# 4R70W/4R75W 4R70E/4R75E

# FORD AOD (FIOD) AOD-E (ELECTRONIC)

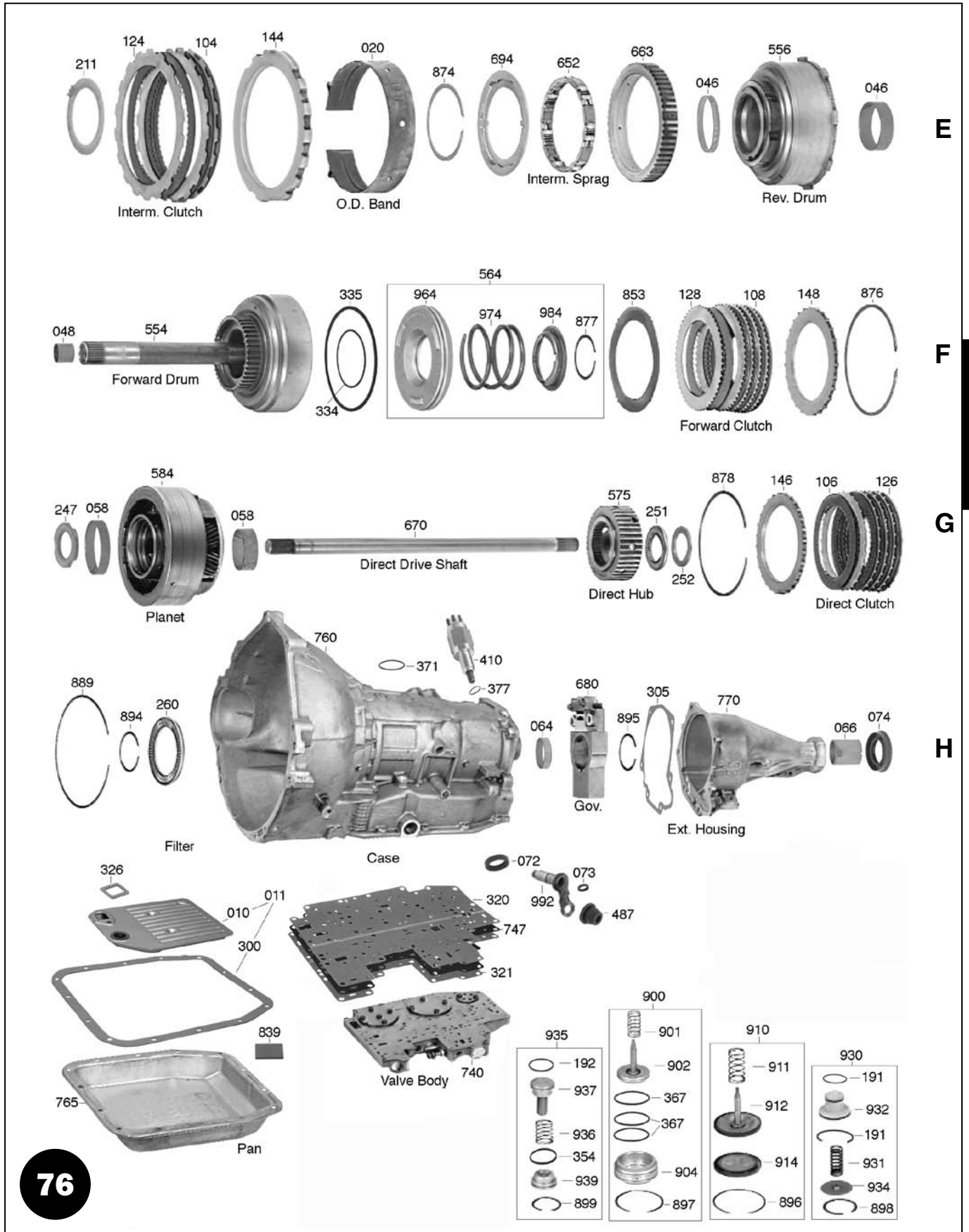

# FORD AOD (FIOD) AOD-E (ELECTRONIC)

# 4R70W/4R75W 4R70E/4R75E

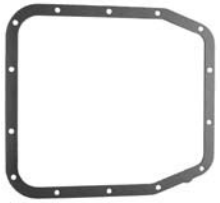

76300



76300E

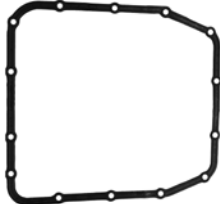

76300EW

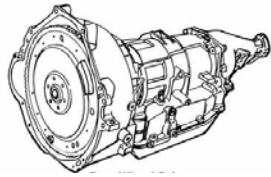

REAR WHEEL DRIVE



76010



76010A



76010E



76010EA

ILL.	DESCRIPTION	QTY.	YEAR	PART NO.	REFERENCE NO.
<b>DELUXE KITS (SUPER KITS) (1)</b>					
008D	AOD (FIOD).....	1	80-E83	76008	K5300-R
008D	AOD (FIOD) (Forward & Direct Frictions are the same).....	1	L83-E89	76008A	K5300A-R
008D	AOD (FIOD) (Forward & Direct Frictions are different).....	1	L89-93	76008B	K5300B-R
008D	AODE (Uses 3 Intermediate .080" Frictions) (76104).....	1	92-95	76008EW	K5300E-R
008D	AODE (Uses 4 Intermediate .066" Frictions) (76104A).....	1	93-95	76008EAW	K5300F-R
008D	4R70W (Uses 4 Intermediate .066" Frictions) (76104A).....	1	93-95	76008EAW	K5300F-R
008D	4R70W.....	1	96-97	76008GW	N/A
008D	4R70W.....	1	98-03	76008HW	K5300G-R
008D	4R70W, 4R75W (w/ Intermediate Piston).....	1	04-Up	76008JW	N/A
<b>COMPLIANCE KITS (CALIFORNIA KITS) (1)</b>					
007D	AOD (FIOD).....	1	80-E83	76007	CK5300-R
007D	AOD (FIOD) (Forward & Direct Frictions are the same).....	1	L83-E89	76007A	CK5300A-R
007D	AOD (FIOD) (Forward & Direct Frictions are different).....	1	L89-93	76007B	CK5300B-R
007D	AODE (Uses 3 Intermediate .080" Frictions) (76104).....	1	92-95	76007EW	CK5300E-R
007D	AODE (Uses 4 Intermediate .066" Frictions) (76104A).....	1	93-95	76007EAW	CK5300F-R
007D	4R70W (Uses 4 Intermediate .066" Frictions) (76104A).....	1	93-95	76007EAW	CK5300F-R
007D	4R70W.....	1	96-97	76007GW	N/A
007D	4R70W.....	1	98-03	76007HW	CK5300G-R
007D	4R70W, 4R75W (w/ Intermediate Piston).....	1	04-Up	76007JW	N/A
<b>MASTER OVERHAUL KITS (WITH STEELS) (1)</b>					
006D	AOD (FIOD).....	1	80-E83	76006	K5300
006D	AOD (FIOD) (Forward & Direct Frictions are the same).....	1	L83-E89	76006A	K5300A
006D	AOD (FIOD) (Forward & Direct Frictions are different).....	1	L89-93	76006B	K5300B
006D	AODE (Uses 3 Intermediate .080" Frictions) (76104).....	1	92-95	76006EW	K5300E
006D	AODE (Uses 4 Intermediate .066" Frictions) (76104A).....	1	93-95	76006EAW	K5300F
006D	4R70W (Uses 4 Intermediate .066" Frictions) (76104A).....	1	93-95	76006EAW	K5300F
006D	4R70W (Might Need Selective Interm Steels).....	1	96-97	76006GW	K5300G
006D	4R70W (Might Need Selective Interm Steels).....	1	98-03	76006HW	K5300G
006D	4R70W, 4R75W (Might Need Selective Interm Steels) (w/ Intermediate Piston).....	1	04-Up	76006JW	K5300H
<b>LESS STEEL KITS (1)</b>					
004D	AOD (FIOD).....	1	80-E83	76004	K5300-LS
004D	AOD (FIOD) (Forward & Direct Frictions are the same).....	1	L83-93	76004A	K5300A-LS
004D	AOD (FIOD) (Forward & Direct Frictions are different).....	1	L89-93	76004B	K5300B-LS
004D	AODE (Uses 3 Intermediate .080" Frictions) (76104).....	1	92-95	76004EW	K5300E-LS
004D	AODE (Uses 4 Intermediate .066" Frictions) (76104A).....	1	93-95	76004EAW	K5300F-LS
004D	4R70W (Uses 4 Intermediate .066" Frictions) (76104A).....	1	93-95	76004EAW	K5300F-LS

# 4R70W/4R75W 4R70E/4R75E

# FORD AOD (FIOD) AOD-E (ELECTRONIC)

ILL.	DESCRIPTION	QTY.	YEAR	PART NO.	REFERENCE NO.
<b>LESS STEEL KITS (1) (Cont.)</b>					
004D	4R70W .....	1	96-97	76004GW	K5300G-LS
004D	4R70W .....	1	98-03	76004HW	K5300G-LS
004D	4R70W, 4R75W (w/ Intermediate Piston) .....	1	04-Up	76004JW	K5300H-LS
<b>OVERHAUL KITS (W/ RINGS &amp; SEALS) (1)</b>					
002D	AOD (FIOD) .....	1	80-93	76002	K53900
002D	AODE, 4R70W .....	1	92-95	76002EW	K53900E
002D	4R70W .....	1	96-03	76002GW	K53900G
002D	4R70W, 4R75W .....	1	04-Up	76002JW	K53900H
<b>GASKET &amp; SEAL KITS (W/O RINGS &amp; SEALS) (1)</b>					
000D	AOD (FIOD) .....	1	80-93	76000	K53900-1
000D	AODE, 4R70W .....	1	92-95	76000EW	K53900E-1
000D	4R70W .....	1	96-03	76000GW	K53900G-1
<b>FILTER KITS (1)</b>					
011H	Filter Kit, AOD (2wd) .....	1	80-93	76011	FK53423
011H	Filter Kit, AOD (4wd) .....	1	84-93	76011A	FK53423A
011H	Filter Kit, AODE, 4R70W (2wd) .....	1	92-95	76011EW	FK53423D
011H	Filter Kit, AODE, 4R70W (2wd) .....	1	96-Up	76011EAW	FK53423C
011H	Filter Kit, AODE, 4R70W (4wd) .....	1	94-Up	76011EAW	FK53423C
<p><b>(1) - To order AOD (FIOD) Kits with Fiber pan gaskets, add an "F" suffix.</b>  <b>If the part number ends in "W", change the "W" to an "F".</b></p>					
<b>FILTERS</b>					
010H	AOD (2wd) .....	1	80-93	76010	53423
010H	AOD (4wd) .....	1	84-93	76010A	53423A
010H	AODE, 4R70W (2wd) .....	1	92-95	76010E	53423D
010H	AODE, 4R70W (2wd) .....	1	96-Up	76010EA	53423C
010H	AODE, 4R70W (4wd) .....	1	94-Up	76010EA	53423C
014	Governor Screen (AOD) .....	1	80-93	76014	53712A
016	Solenoid Screen (AODE, 4R70W) (Small Square Filter In Valve Body) .....	1	92-Up	76016	53712B
<b>BANDS</b>					
<b>Prefix Key: B = Borg Warner, A = OEM (Exc. BW), N = All Other New, R = Relined</b>					
020E	Overdrive (AOD) .....	1	80-93	76020	53320
020E	Overdrive (AOD) (Kevlar) .....	1	80-93	76020K	53320X
020E	Overdrive (AODE, 4R70W) .....	1	92-Up	76020E	53320A
020E	Overdrive (AODE, 4R70W) (Heavy Duty) .....	1	92-Up	76020G	53320AX
024C	Reverse .....	1	80-Up	76024	53520
<b>BUSHINGS</b>					
030D	Bushing Kit (w/ Cast Iron Drums) .....	1	80-91	76030	K53905
030D	Bushing Kit (w/ Stamped Steel Drums) .....	1	92-93	76030A	K53905A
030D	Bushing Kit (w/ Stamped Steel Drums) .....	1	94-Up	76030B	K53905B
034A	Pump (.758" Wide) .....	1	80-Up	36034	36002A
034A	Pump (.697" Wide) .....	1	80-Up	76034	73002
036A	Stator (Front) .....	1	92-93	36036	36000A
036A	Stator (Front) (2 Groove) .....	1	94-Up	76036	36000B
037A	Stator (Rear) .....	1	80-91	76037	53000
037A	Stator (Rear) w/o Notch .....	1	92-Up	36036	36000A
037A	Stator (Rear) w/ Notch .....	1	92-Up	76037B	36001B
038D	Direct Drum (Cast Iron Drum) (can use 76038A) .....	1	80-89	76038	53012A
038D	Direct Drum (Stamped Steel Drum) (Replaces 76038) .....	1	80-Up	76038A	53012A

AOD/AODE

# FORD AOD (FIOD) AOD-E (ELECTRONIC)

# 4R70W/4R75W 4R70E/4R75E

ILL.	DESCRIPTION	QTY.	YEAR	PART NO.	REFERENCE NO.
<b>BUSHINGS (Cont.)</b>					
044C	Center Support.....	1	80-Up	76044	53009
046E	Reverse Clutch Drum (Rear).....	1	80-Up	76046	53003
046E	Reverse Clutch Drum (Front).....	1	80-Up	76046B	53002
048F	Forward Drum Shaft.....	1	80-93	76048	53005
051C	Reverse Sun Gear (Shell).....	2	80-Up	76051	53008
052C	Forward Sun Gear.....	1	80-Up	76052	53006
058G	Planet (Rear) (1.380" OD).....	1	80-Up	76058	53011
058G	Planet (Front) (2.770" OD).....	1	80-Up	76058B	53010
064H	Case.....	1	80-Up	76064	53007
064H	Case (Top Hat, Replaces Case Bushing).....	1	80-Up	76064B	53007X
066H	Extension Housing 1.506" ID (Babbitt).....	1	80-92	26066	6014
066H	Extension Housing 1.506" ID (Bronze).....	1	80-92	76066A	6014
066H	Extension Housing 1.606" ID (Bronze) (4R70W).....	1	93-Up	76066B	53014
Tool	Bore Repair Sleeve, Case (2.00" Long) (AOD) (requires T-1695).....	1	80-Up	T-1695-SL	T-1695-SL
Tool	Bore Repair Sleeve, Case (1.50" Long) (AOE, 4R70W) (requires T-1695).....	1	80-Up	T-1695-SLE	T-1690-SL-E
<b>METAL CLAD SEALS</b>					
070A	Front (w/o Flange).....	1	80-Up	36070	16601B
070A	Front (Black w/ Flange) (Designed for Aluminum Pump w/ Locking Ribs).....	1	92-Up	76070A	53601
072H	Linkage Shaft to Case.....	1	80-Up	36072	6507A
073H	Throttle Lever (AOD).....	1	80-93	76073	53697
074H	Rear (w/o Boot) (AOD, AOAE).....	1	80-92	44074	8850B
074H	Rear (w/ Long Boot) (AOD, AOAE).....	1	80-Up	26074	16695E
074H	Rear (w/ Short Boot) (AOD, AOAE).....	1	80-Up	26074A	16695ES
074H	Rear (w/ Short Boot) (2.487" OD) (4R70W).....	1	93-Up	76074A	53695E
<b>FRICTION PLATES</b>					
104E	Intermediate (.080") (AOD, AOAE).....	3	80-95	76104	53204
104E	Intermediate (.080") (AOD, AOAE) (Hi-Performance) (Blue).....	AR	80-95	R76104HP	53204X
104E	Intermediate (.080") (AOD, AOAE) (Hi-Performance) (Red).....	AR	80-95	A76104HP	53204R
104E	Intermediate (.066") (4R70W) (Smooth).....	3	93-97	76104A	53204A
104E	Intermediate (.066") (4R70W, 4R75W) (Grooved).....	4	98-Up	76104B	53204B
104E	Intermediate (.066") (4R70W) (Hi-Performance) (Blue).....	AR	93-Up	R76104AHP	53204AX
104E	Intermediate (.066") (4R70W) (Hi-Performance) (Red).....	AR	93-Up	A76104AHP	53204AR
106G	Direct (.075").....	5	80-97	76106	53304
106G	Direct (.075") (Hi-Performance) (Blue).....	AR	80-97	R76106HP	53304X
106G	Direct (.075") (Hi-Performance) (Red).....	AR	80-97	A76106HP	53304R
106G	Direct (.068").....	6	97-Up	76106E	53304A
106G	Direct (.072") (Hi Energy).....	4	80-Up	76106A	53304H
106G	Direct (.068") (Hi-Performance) (Red).....	AR	97-Up	A76106EHP	53304AR
106G	Direct (.059") (Commercial).....	AR	80-93	76106C	N/A
108F	Forward (5.25" OD).....	5	80-89	76108A	53404
108F	Forward (5.25" OD) (Hi-Performance) (Blue).....	AR	80-89	R76108AHP	53404X
108F	Forward (5.25" OD) (Hi-Performance) (Red).....	AR	80-89	A76108AHP	53404R
108F	Forward (5.36" OD) (For Stamped Steel Drums).....	5	90-Up	76108B	53404A
108F	Forward (5.36" OD) (For Stamped Steel Drums) (Hi-Performance) (Red).....	AR	80-89	A76108BHP	53404AR
110B	Reverse (.080").....	4	80-L83	76108	53504
110B	Reverse (.061").....	5	L83-Up	76108A	53404
110B	Reverse (.061") (Hi-Performance) (Blue).....	AR	L83-Up	R76108AHP	53404X
104E	Intermediate Friction Kit, (.080") High Performance.....	1	80-97	A76104HPK	N/A
106G	Direct Friction Kit, (.075") High Performance.....	1	80-97	A76106HPK	N/A
106G	Friction & Steel Kit (AOD) Direct (.075") (Kolene Steels, w/ Pressure Plate).....	1	80-93	A76106PK	N/A
106G	Friction & Steel Kit (AOD) Direct (.059") Commercial (w/ Pressure Plate).....	1	80-93	A76106CPK	K53-53
106G	Friction & Steel Kit (AOAE) Direct (.059") Commercial (w/ Pressure Plate).....	1	92-Up	A76106EPK	K53-53B
108F	Forward Friction Kit (.061") (High Performance).....	1	80-Up	A76108HPK	N/A
110B	Reverse Friction Kit (.061") (High Performance).....	1	84-Up	A76108HPK	N/A

**4R70W/4R75W  
4R70E/4R75E**

**FORD AOD (FIOD)  
AOD-E (ELECTRONIC)**

ILL.	DESCRIPTION	QTY.	YEAR	PART NO.	REFERENCE NO.
<b>STEEL PLATES</b>					
124E	Intermediate (.069") .....	3	80-Up	76124	53205
124E	Intermediate (.069") (Kolene) .....	AR	80-Up	76124D	53205K
124E	Intermediate (.079") .....	AR	80-Up	76124A	53205A
124E	Intermediate (.089") .....	AR	80-Up	76124B	53205B
124E	Intermediate (.097") .....	AR	80-Up	76124C	53205C
126G	Direct (.070") (28 T) .....	4	80-89	76126	53305
126G	Direct (.070") (28 T) Kolene .....	AR	80-Up	76126D	53305K
126G	Direct (.060") (28 T) Commercial .....	AR	80-89	76126C	53305X
126G	Direct (.070") (34 T) Stamped Steel Drum .....	5-6	90-99	76126A	53305A
126G	Direct (.079") (34 T) Stamped Steel Drum .....	1	98-Up	76126E	53305B
128F	Forward (.068") (54 T) Cast Iron Drum .....	5	80-89	76128	6205
128F	Forward (.068") (54 T) Kolene .....	8	80-89	76128D	6205K
128F	Forward (.069") (34 T) Stamped Steel Drum .....	5	90-Up	76128A	53405A
130B	Reverse (.068") (54 T) Cast Iron Drum .....	3	80-89	76128	6205
130B	Reverse (.068") (54 T) Kolene .....	8	80-89	76128D	6205K
130B	Reverse (.069") (32 T) Stamped Steel Drum .....	3-4	90-Up	76128B	53505A
853F	Cushion, Forward Clutch (w/ Cast Iron Drum) .....	1	80-Up	76853	53420
853F	Cushion, Forward Clutch (w/ Stamped Steel Drum) .....	1	89-98	76853B	53420A
124E	Intermediate Steel Kit (Kolene) (Hi-Performance) .....	1	80-Up	A76124HPK	N/A
126G	Direct Steel Kit (Kolene) (Hi-Performance) .....	1	80-Up	A76126HPK	N/A
139	Steel Module (AOD) .....	1	80-E89	76139	N/A
139	Steel Module (AOD) .....	1	L89-93	76139B	N/A
139	Steel Module (AODE) .....	1	92-95	76139E	N/A
139	Steel Module (4R70W) .....	1	93-97	76139G	N/A
139	Steel Module (4R70W, 4R75W) .....	1	98-Up	76139H	N/A
<b>PRESSURE PLATES</b>					
<b>Prefix Key: D = OEM, A = Aftermarket New, R = Remanufactured</b>					
144E	Intermediate (.406") .....	1	80-93	76144	53415F
144E	Intermediate (.258") .....	1	93-Up	76144E	53415G
146G	Direct (.220") (28 T) (Cast Drum) .....	1	80-E89	76146	53415A
146G	Direct (.128") (28 T) Commercial .....	1	80-E89	76146C	N/A
146G	Direct (.220") (34 T) (Steel Drum) .....	1	L89-Up	76146A	53415D
148F	Forward (.115") (34 T) (Steel Drum) .....	1	80-Up	76148A	53415E
150B	Reverse (Top) (.200") (27 T) Flat (Cast Drum) .....	1	80-89	76150	53416D
150B	Reverse (Top) (.200") (34 T) Beveled (Steel Drum) .....	1	90-Up	76150A	53416B
151B	Reverse (Bottom) (.100") Beveled (Cast Drum) .....	1	80-89	76151	53416C
151B	Reverse (Bottom) (.100") Beveled (Steel Drum) .....	1	90-Up	76151A	53416
<b>VALVE BODY RECALIBRATION KITS</b>					
165D	Shift Kit® (AOD) (Transgo®) .....	1	80-93	T76165	K53908
165D	Shift Kit® (AODE) (Transgo®) .....	1	91-04	T76165E	K53908E
165D	Reprogramming Kit™ (AOD), HD & Hi-Perf (Transgo®) .....	1	83-93	T76171	AOD-HP
165D	Reprogramming Kit™ (AODE), HD & Hi-Perf (Transgo®) .....	1	91-Up	T76171E	AODE-HD2
165D	Reprogramming Kit™ (AODE), Full Manual Control - Stick Shift (Transgo®) .....	1	91-Up	T76173E	N/A
165D	Shift Correction Package (AOD) (Superior) .....	1	80-93	S76165	53C01
165D	Shift Correction Package (AOD) Hi-Perf (Superior) .....	1	80-Up	S76171	53C-HP
165D	Shift Correction Package (AODE) (Superior) .....	1	92-Up	S76165E	53C02
165D	Sure Cure Kit (AODE) (Sonnax) .....	1	92-95	S76174	53S02
165D	Sure Cure Kit (AODE, 4R70W) (Sonnax) .....	1	96-Up	S76174A	53S03
<b>SEALING RINGS</b>					
175D	Ring Kit (AOD) .....	1	80-93	76175A	K53901A
175D	Ring Kit (AODE, 4R70W) .....	1	92-03	76175E	K53901E
177	Input Shaft 1.130" OD (Scarf Cut) (Teflon) .....	2	92-Up	76177ET	N/A

AOD/AODE

# FORD AOD (FIOD) AOD-E (ELECTRONIC)

# 4R70W/4R75W 4R70E/4R75E

ILL.	DESCRIPTION	QTY.	YEAR	PART NO.	REFERENCE NO.
<b>SEALING RINGS (Cont.)</b>					
177	Input Shaft 1.130" OD (Solid) (Teflon) .....	2	92-Up	76177EAT	53233S
179A	Stator (Reverse Clutch) 2.624" OD (Metal) .....	2	80-Up	76179	53226
180D	Output Shaft (Direct Clutch) .914" OD (Metal).....	2	80-Up	76180	53224
180D	Output Shaft (Direct Clutch) .914" OD (Teflon) (Scarf Cut).....	2	80-Up	76180T	N/A
180D	Output Shaft (Direct Clutch) .914" OD (Teflon) (Solid).....	2	80-Up	54177DBT	N/A
181A	Stator (Forward Clutch) 2.374" OD (Metal) .....	2	80-92	76181	53225
181A	Stator (Forward Clutch) 2.374" OD (Metal, Hardened) .....	2	93-Up	76181E	53225H
181A	Stator (Forward Clutch) (Plastic) .....	2	04-Up	76181G	53225P
189D	Governor 1.752" OD (Metal, Cast Iron) .....	4	80-Up	76189	53645
189D	Governor 1.752" OD (Metal, Seal Plated).....	3-4	80-Up	76189A	53645A
<b>THRUST WASHERS</b>					
200D	Washer Kit (Washers Only).....	1	80-Up	76200	K53907
200D	Washer Kit (Selective Washers Only) .....	1	80-Up	76200B	N/A
211E	Stator .052" (#1) Green .....	1	80-Up	76211	53409
211E	Stator .070" (#2) Yellow .....	1	80-Up	76211A	53409A
211E	Stator .087" (#3) Natural.....	1	80-Up	76211B	53409B
211E	Stator .104" (#4) Red .....	1	80-Up	76211C	53409C
211E	Stator .121" (#5) Blue.....	1	80-Up	76211D	53409D
247G	Rear Planet (Bronze) (Bearing Replacement).....	1	80-Up	76247A	53753A
251G	Direct Drum to Hub (Bronze, Aftermarket) .....	1	80-Up	76251A	N/A
257B	Reverse Drum to Forward Drum .....	1	80-84	76257	53411
<b>BEARINGS &amp; RACES</b>					
201D	Bearing Kit (AOD).....	1	80-93	76201A	K53906
201D	Bearing Kit (AOE) (76260A Not Included) .....	1	92-Up	76201E	K53906A
201D	Bearing Kit (4R70W) (76260A Included).....	1	93-03	76201EA	K53906B
229D	Bearing, Direct Drum to Rear Ring Gear Hub (AOD) .....	1	80-93	76229	53752
229D	Bearing, Direct Drum to Rear Ring Gear Hub (AOE) .....	1	92-Up	76229B	53752W
232C	Bearing, Forward Clutch Drum to Hub (Front) .....	1	80-Up	36238A	53751
235C	Bearing, Sun Shell (Front).....	1-2	80-Up	76235	53750
244C	Bearing, Sun Shell to Forward Sun Gear (.130") (AOD) .....	1	80-93	76235	53750
244C	Bearing, Sun Shell to Forward Sun Gear (.170") (AOE, 4R70W) .....	1	92-03	76244B	53750W
244C	Bearing, Sun Shell to Forward Sun Gear (.205") (AOE, 4R70W) .....	1	03-Up	76235B	53750B
247G	Bearing, Rear Planet (Inside Planet) .....	1	80-Up	76251	53754
251G	Bearing, Direct Drum to Hub.....	1	80-Up	76251	53754
252G	Race, Direct Drum to Hub .....	1	80-Up	76252	53755W
257B	Bearing, Reverse Drum to Forward Drum.....	1	83-Up	76257A	53411A
260H	Bearing w/ 1 Race, Rear Support to Case.....	1	80-91	76260	53753
260H	Bearing w/ Races, Rear Support to Case .....	1	92-Up	76260A	53753W
<b>GASKETS &amp; O-RINGS</b>					
300H	Gasket, Pan (AOD) (Cork).....	1	80-93	76300	13975X
300H	Gasket, Pan (AOD) (Fiber) .....	1	80-93	76300F	13975F
300H	Gasket, Pan (AOE, 4R70W) (Cork) .....	1	92-Up	76300E	13975AX
300H	Gasket, Pan (AOE, 4R70W) (Fiber).....	1	92-Up	76300EF	13975AF
300H	Gasket, Pan (AOE, 4R70W) (Bonded Gasket) .....	1	92-Up	76300EW	13975AR
305H	Gasket, Extension Housing .....	1	80-Up	76305	13866
305H	Gasket, Extension Housing (Silicone Beaded) .....	1	92-Up	76305G	13866M
310A	Gasket, Pump (AOD).....	1	80-93	76310	13851
310A	Gasket, Pump (AOE, 4R70W) .....	1	92-Up	76310A	13851A
311A	O-Ring, Front Pump .....	1	80-Up	76311	13850
320H	Gasket, Valve Body (Upper) White Stripe.....	1	80-93	76320	13861
320H	Gasket, Valve Body (Upper) (Thick) .....	1	80-93	76320-1	13861T
320H	Gasket, Valve Body (Upper) Yellow Stripe .....	1	92-95	76320E	13861C
320H	Gasket, Valve Body (Upper) Light Green Stripe.....	1	96-Up	76320EA	13861D

ILL.	DESCRIPTION	QTY.	YEAR	PART NO.	REFERENCE NO.
<b>GASKETS &amp; O-RINGS (Cont.)</b>					
321H	Gasket, Valve Body (Lower) White Stripe .....	1	80-89	76321	13860
321H	Gasket, Valve Body (Lower) (Thick) .....	1	80-89	76321-1	13860T
321H	Gasket, Valve Body (Lower) White or Orange Stripe .....	1	96-00	76321EA	13860D
321H	Gasket, Valve Body (Lower) Yellow Stripe .....	1	80-Up	76321B	13860B
321H	Gasket, Valve Body (Lower) Light Green Stripe .....	1	92-95	76321E	13860C
321H	Gasket, Valve Body (Lower) Light Blue Stripe .....	1	01-Up	76321EB	13860E
322	Gasket, Valve Body Cover (AODE) .....	1	92-95	76322E	13871
322	Gasket, Valve Body Cover (AODE, 4R70W) .....	1	96-Up	76322EA	13871A
326H	Gasket, Filter (AOD) .....	1	80-93	76326	13868
332A	Lip Seal, Intermediate Clutch (Inner) .....	1	80-Up	76332	N/A
333A	Lip Seal, Intermediate Clutch (Outer) .....	1	80-Up	76333	N/A
334F	Lip Seal, Forward Clutch (Inner) .....	1	80-Up	76334	13943
335F	Lip Seal, Forward Clutch (Outer) .....	1	80-Up	76335	13944
336D	Lip Seal, Direct Clutch (Inner) .....	1	80-Up	76336	13941
337D	Lip Seal, Direct Clutch (Outer) .....	1	80-Up	76337	13942
338B	Lip Seal, Reverse Clutch (Inner) .....	1	80-Up	76338	N/A
339B	Lip Seal, Reverse Clutch (Outer) .....	1	80-Up	76339	N/A
352	O-Ring, 1-2 Accumulator (Small) (AOD) .....	1	80-93	76352	N/A
367H	Lathe Cut Seal, Overdrive Servo Cover .....	2	80-Up	76367	13236D
367H	O-Ring, Overdrive Servo Piston 1.937" .....	1	80-93	76367A	N/A
367H	O-Ring, Overdrive Servo Piston 2.250" .....	1	80-93	76367AA	N/A
371H	O-Ring, Filler Tube .....	1	80-Up	44371A	3291L
378	O-Ring, Cooler Line (Viton) Push In Type .....	1	80-Up	76378V	N/A
390	External Seal Kit (AOD) .....	1	80-93	76390	SK53900-2
<b>TECHNICAL MANUALS</b>					
400D	Tech Manual (AOD) .....	1	80-93	76400	53Y01
400D	Tech Manual (AODE, 4R70W) .....	1	92-Up	76400E	53Y02
400D	Tech Manual (AODE, 4R70W) Update Handbook .....	1	92-Up	76400H	53Y04
<b>ELECTRICAL COMPONENTS</b>					
410H	Switch, Neutral Safety (4 Prong) .....	1	80-89	56410A	15A-264
410H	Switch, Neutral Safety (5 Prong) .....	1	90-93	76410B	15A-266
410H	Sensor, MLPS (8 Pin) Update Pack (Exc. Crown Victoria) .....	1	92-97	76410E	15A-267
410H	Sensor, MLPS (8 Pin, .860" Bolt Insert) (Crown Victoria 95-10/97) .....	1	95-L97	76410EB	15A-268
410H	Sensor, DTR (12 Pin, .860" Bolt Insert) (Crown Victoria 11/97-Up) .....	1	L97-Up	76410EC	15A-269
410H	Sensor, DTR (12 Pin, .530" Bolt Insert) .....	1	98-Up	76410EA	15A-269A
416	Shudder Eliminator, TCC (Circuit Board) (AODE, 4R70W) .....	1	92-97	76416A	30A-325
420	Solenoid Master Kit (AODE) .....	1	92-94	76420EK	31T-AODE
420	Solenoid Master Kit (AODE) .....	1	95-97	76420EAK	31T-AODEB
420	Solenoid, Shift (Dual, Soft Wire) (Teckpak) .....	1	92-97	T76420	5T-156
421	Solenoid, Shift (Dual, Soft Wire) (Rostra) .....	1	92-97	76421	5R-156
421	Solenoid, Shift (Dual, Soft Wire) .....	1	92-97	D76421	5A-156A
421	Solenoid, Shift (Dual, Hard Wire) .....	1	98-Up	76421A	5A-156C
425	Solenoid, Lock-Up (TCC) (Soft Wire, Black Connector) (Teckpak) .....	1	92-94	T76425	5T-157
425	Solenoid, Lock-Up (TCC) (Soft Wire, Black Connector) .....	1	92-94	76425B	5A-157
425	Solenoid, Lock-Up (TCC) (Soft Wire, White Connector) (Teckpak) .....	1	95-97	T76425BA	5T-157A
425	Solenoid, Lock-Up (TCC) (Soft Wire, White Connector) (Rostra) .....	1	95-97	76430B	5R-157A
425	Solenoid, Lock-Up (TCC) (Soft Wire, White Connector) .....	1	95-97	76425BA	5A-157A
425	Solenoid, Lock-Up (TCC) (Hard Wire) .....	1	98-Up	76425BB	5A-157C
431	Solenoid, EPC (Soft Wire) (92-95 uses D76843 Bracket, 96-Up uses D76843A) .....	1	92-97	76431	5A-158A
431	Solenoid, EPC (Hard Wire) Green or Red Connector (When Out Use 76431B) .....	1	98-04	76431A	N/A
431	Solenoid, EPC (Hard Wire) Tan or Mustard Connector .....	1	98-04	76431B	5A-158C
431	Solenoid, EPC (Hard Wire) Black Connector .....	1	05-Up	76431C	5A-158E
436	Sensor, Output Speed (VSS) (Cable Design) .....	1	84-Up	36436	20A-412
436	Sensor, Output Speed (VSS) (Non Cable Design) .....	1	89-Up	86436A	20A-412A



# FORD AOD (FIOD) AOD-E (ELECTRONIC)

# 4R70W/4R75W 4R70E/4R75E

ILL.	DESCRIPTION	QTY.	YEAR	PART NO.	REFERENCE NO.
<b>ELECTRICAL COMPONENTS (Cont.)</b>					
436	Sensor, Output (Case) (Rectangular Connector) .....	1	92-01	76436A	20A-415
436	Sensor, Output (Case) (Square Connector) (01-03).....	1	01-03	76436B	20A-415B
436	Sensor, Output (Case) (Square Connector) (04-Up) .....	1	04-Up	76436C	20A-415C
436	Sensor, RWD (Differential) (Various Applications) .....	1	90-Up	36436B	20A-300
437	Sensor, Transmission Oil Temperature (TOT).....	1	92-Up	86437	20A-104
438	Sensor, Center Case (4R70E, 4R75E).....	1	04-Up	76438	20A-415E
444	Connector, Case w/ Harness (Soft Wire).....	1	92-97	76446A	25A-150
444	Connector, Case (Hard Wire) (Connector Only) .....	1	98-Up	76444A	25A-151
446	Wire Harness, Internal (Hard Wire) .....	1	98-Up	76446E	25A-152
446	Wire Harness, Internal (Hard Wire) (Rostra).....	1	98-Up	A76446E	25R-152
445	Wire Harness External (Repair) (Case Connector, Solenoid) (AODE).....	1	92-97	86445EC	35A-254
445	Wire Harness External (Repair) (Case Connector, Solenoid) (AODE) (Rostra).....	1	92-97	86445EHK	35R-254
445	Wire Harness External (Repair) (Case Connector, Speed Sensor) (AODE) .....	1	92-97	76445C	35A-255
445	Wire Harness External (Repair) (MLPS 8 Pin) .....	1	95-96	76445DK	35A-267
445	Wire Harness External (Repair) (DTR 12 Pin).....	1	97-Up	76445EK	35A-269
<b>HARD PARTS</b>					
<b>Prefix Key: D = OEM, A = Aftermarket New, R = Remanufactured</b>					
<b>PUMPS</b>					
500A	Pump (AOD) .....	1	80-93	76500	53200
500A	Pump (AODE) .570" Pump Gears (Can Use 76500B).....	1	92-94	76500A	53200A
500A	Pump (AODE) .608" Pump Gears .....	1	95-03	76500B	53200W
507D	Stator Support Sleeve .....	1	80-Up	76507S	N/A
510A	Pump Body & Gears (AOD) (Cast Iron) .....	1	80-93	76510	53300
510A	Pump Body w/ .570" Gears (Aluminum) (Can Use 76510B) .....	1	92-94	76510A	53300A
510A	Pump Body w/ .608" Gears (Aluminum).....	1	95-03	76510B	53300W
520A	Stator, Pump (AOD) .....	1	80-93	76520	53400
520A	Stator, Pump (AODE, 4R70W, 4R75W).....	1	92-Up	76520A	53400W
530A	Pump Gears (.660" Thick) (AOD).....	1	80-93	36530	K36201
530A	Pump Gears (.569" Thick).....	1	92-93	76530A	K53201
530A	Pump Gears (.608" Thick).....	1	94-Up	76530B	K53201W
<b>DRUMS &amp; CLUTCH HUBS</b>					
554F	Forward w/ Hollow Input Shaft (5 Clutch) (Cast Iron).....	1	80-93	76554	53927
554F	Forward w/ Hollow Input Shaft (5 Clutch) (Stamped Steel).....	1	89-93	76554A	53927A
554F	Forward w/ Solid Shaft (Stamped Steel) .....	1	92-Up	76554C	53927B
554F	Forward w/ Solid Shaft (Stamped Steel) (Incl 4R70E, 4R75E).....	1	92-Up	D76554C	N/A
555D	Direct (5 Clutch) (Cast Iron or Steel) (28 T Steels) .....	1	82-93	76555CA	53726A
555D	Direct (6 Clutch) (Cast Iron) .....	1	82-93	76555CB	53726B
555D	Direct (6 Clutch) (Stamped Steel) (34 T Steels) .....	1	92-98	76555D	53726C
555D	Spiral Snap Ring for Direct Drum Shaft.....	1	80-Up	76555-4	53953S
555D	Snap Ring for Intermediate Sprag Retainer (Superior Spiral) .....	1	80-Up	A76874A	53962S
556E	Reverse (3 Clutch) (Cast Iron) w/o Sprag (Uses a Washer # 257).....	1	80-E83	76556B	53961A
556E	Reverse (3 Clutch) (Cast Iron) w/o Sprag (Uses a Bearing # 257).....	1	L83-93	76556C	53961C
556E	Reverse (4 Clutch) (Cast Iron) w/o Sprag (Uses a Washer # 257).....	1	80-E83	76556	53961
556E	Reverse (4 Clutch) (Cast Iron) w/o Sprag (Uses a Bearing # 257).....	1	L83-93	76556A	53961B
556E	Reverse (4 Clutch) (Stamped Steel) uses 7 Roller Sprag (w/o Sprag).....	1	92-Up	76556D	53961D
556E	Reverse (4 Clutch) (Stamped Steel) uses 14 Roller Sprag (w/o Sprag).....	1	92-97	76556E	53961W
556E	Reverse (4 Clutch) (Stamped Steel) (w/o Ratchet Design Sprag).....	1	98-Up	76556G	53961M
556E	Reverse Drum Kit (4 Clutch) (Stamped Steel) (w/ Ratchet Design Sprag) .....	1	98-Up	76556GK	K53961M
574C	Clutch Hub, Forward Clutch (AOD) .....	1	80-93	76574	53944
574C	Clutch Hub, Forward Clutch.....	1	92-Up	76574A	53944
575G	Clutch Hub, Direct Clutch (Cast# AB) (AOD).....	1	83-93	76575AA	53945
575G	Clutch Hub, Direct Clutch (Cast# F30) .....	1	92-Up	76575B	53945

**4R70W/4R75W  
4R70E/4R75E**

**FORD AOD (FIOD)  
AOD-E (ELECTRONIC)**

ILL.	DESCRIPTION	QTY.	YEAR	PART NO.	REFERENCE NO.
<b>DRUMS &amp; CLUTCH HUBS (Cont.)</b>					
562A	Piston Kit, Intermediate Clutch.....	1	80-Up	76562	N/A
564F	Piston Kit, Forward Clutch (AOD).....	1	80-93	76564	N/A
564F	Piston Kit, Forward Clutch.....	1	92-Up	76564A	N/A
565D	Piston Kit, Direct Clutch (AOD).....	1	80-93	76565	N/A
565D	Piston Kit, Direct Clutch.....	1	92-Up	76565A	N/A
565D	Piston Kit, Direct Clutch (Fits 76555BB & 76555D Drums).....	1	80-Up	76565B	N/A
566B	Piston Kit, Reverse Clutch .414" (AOD).....	1	80-93	76566	N/A
566B	Piston Kit, Reverse Clutch .494".....	1	92-Up	76566A	N/A
<b>PLANETS</b>					
584G	Planet (AOD, AODE) (Top Cover is 4.750" OD).....	1	80-Up	76584A	53730
584G	Planet (4R70W) (Top Cover is 4.845" OD) (Riveted).....	1	93-Up	76584B	53730W
584G	Planet (4R70W) (Top Cover is 4.845" OD) (Welded).....	1	04-Up	76584C	53730E
594D	Ring Gear (72 T w/o Holes) (AOD).....	1	80-93	76594	53735
594D	Ring Gear (72 T w/ Holes) (AODE).....	1	92-Up	76594A	53735A
594D	Ring Gear (88 T w/ Holes) (4R70W).....	1	92-Up	76594B	53735W
594D	Ring Gear (88 T w/o Holes) (4R75E, 4R75W).....	1	04-Up	76594D	53735E
604D	Hub, Ring Gear (5.380" OD) (Raised Surface Where Bearing #229 Rides).....	1	80-91	76604	53947
604D	Hub, Ring Gear (5.380" OD) (Lowered Surface Where Bearing # 229 Rides).....	1	92-95	76604AA	53947A
604D	Hub, Ring Gear (5.160" OD) (4R70W).....	1	93-Up	76604C	53947W
<b>SUN GEARS, SHELLS &amp; SUPPORTS</b>					
612C	Sun Gear, Forward (30 T) (not included in the Sun Gear & Shell Kit).....	1	80-Up	76612	53949
612C	Sun Gear, Forward (31 T) (4R70W) (not incl in the Sun Gear & Shell Kit).....	1	92-Up	76612A	53949W
612C	Sun Gear, Forward (31 T) (4R70E, 4R75E) (not incl in the Sun Gear & Shell Kit).....	1	03-Up	76612B	53949E
624C	Shell w/ Front Sun Gear (36 T) Magnetic (AOD) (Cast Reverse Drum Type).....	1	80-90	76624	53948
624C	Shell w/ Front Sun Gear (36 T) Magnetic (AODE) (Steel Reverse Drum Type).....	1	90-95	76624A	53948A
624C	Shell w/ Front Sun Gear (38 T) Magnetic (4R70W, 4R75W).....	1	93-03	76624B	53948W
624C	Shell w/ Front Sun Gear (38 T) Non Magnetic (4R70E/W, 4R75E/W).....	1	04-Up	76624C	53948E
624C	Kit, Shell w/ Front & Forward Sun Gear (Magnetic) (4R70W, 4R75W).....	1	93-Up	76624BK	K53948W
630C	Center Support.....	1	80-03	76630	53950
639C	Spring, Anti-Clunk.....	1	80-Up	76639	N/A
<b>SPRAGS</b>					
652E	Sprag, Intermediate (7 Roller).....	1	80-97	76652B	53960B
652E	Sprag, Intermediate (14 Roller).....	1	92-97	76652A	53960A
652E	One Way Clutch, Ratchet Design (4R70W) Intermediate (14 Inner Splines).....	1	98-Up	76652C	53960M
654C	Sprag, Low Roller Clutch (Rear).....	1	80-Up	34654	34402A
663E	Outer Race, Intermediate Sprag (7 Roller).....	1	80-97	76663	53931
663E	Outer Race, Intermediate Sprag (14 Roller).....	1	92-97	76663B	53931W
663E	Outer Race Kit (Ratchet Design, 76694A, 76874 & Reverse Drum).....	1	98-Up	76556GK	K53961M
<b>SHAFTS</b>					
670G	Shaft, Direct Drive (AOD).....	1	80-93	76670	53994
670G	Shaft, Direct Drive (AODE, 4R70W).....	1	92-Up	76670A	53725
678D	Output Shaft (4wd) (AOD).....	1	92-Up	76678H	53991B
678D	Output Shaft (2wd) (AOD) (8 T Spd-O-Gr).....	1	80-87	76678DA	53991A
<b>GOVERNORS</b>					
680H	Governor, w/ Weight (AOD).....	1	80-93	76680	53992
681H	Spring, Governor (AOD).....	1	80-Up	106681A-3	6242CS
694E	Retainer, Intermediate Sprag (7 Roller Sprag).....	1	80-92	76694	53963
694E	Retainer, Intermediate Sprag (14 Roller Sprag).....	1	93-Up	76694A	N/A

AOD/AOD-E

# FORD AOD (FIOD) AOD-E (ELECTRONIC)

# 4R70W/4R75W 4R70E/4R75E

ILL.	DESCRIPTION	QTY.	YEAR	PART NO.	REFERENCE NO.
<b>VALVE BODIES</b>					
740H	Valve Body (Premium) AOD (w/ 4th Accum.).....	1	80-87	76740-7	P53990B
740H	Valve Body (Premium) AOD (No 4th Accum.) .....	1	87-93	76740-8	P53990C
740H	Valve Body (Premium) AODE Cast F2 .....	1	1992	76740-5	P53990E
740H	Valve Body (Premium) AODE Cast F3 .....	1	93-95	76740-6	P53990D
740H	Valve Body (Premium) 4R70W (w/ 2/3 Accum Plate) (Wired Harness) Cast F6 .....	1	96-97	76740-2	P53990F
740H	Valve Body (Premium) 4R70W (w/ 2/3 Accum Plate) (Solid Harness) Cast F6 .....	1	98-00	76740-1	P53990G
740H	Valve Body (Premium) 4R70W (No 2/3 Accum Plate) .....	1	00-Up	76740-9	P53990J
<b>VALVE BODY COMPONENTS</b>					
741D	Alignment Pin Adapters (4R70W) allows 96-Up VB's to be used in 93-95 Cases.....	1	93-Up	A76741A-2	T-9014B
741D	By-pass Kit, Clutch Control Sleeve & Plunger (AODE, 4R70W) .....	1	92-Up	76741AK	K53977E
741D	Check Ball, Valve Body (1/4").....	7	80-Up	76741A-5	13924
741D	Check Ball, Valve Body (5/16").....	7	80-Up	76741-5	13924A
741D	Plug Kit, Governor Circuit End .....	1	80-E83	76741-6AK	N/A
741D	Plug Kit, Governor Circuit End .....	1	L83-93	76741-6BK	K53978D
741D	Plug Kit, O-Ringed End Large (Uses ORMK-4) .....	1	80-Up	76741-6KL	K53978L
741D	Plug Kit, O-Ringed End Medium.....	1	80-Up	76741-6KM	K53978M
741D	Plug Kit, O-Ringed End Small .....	1	80-Up	76741-6KS	K53978S
741D	Spring, 1-2 Accumulator (10 Per Bag) (AOD) .....	1	80-93	76741E-3	53709
741D	Spring, Elevated Pressure Regulator (AODE) (Bag of 5).....	1	91-95	76741P-3	53975S
741D	Valve, Overdrive Servo Regulator Boost (4R70W) .....	1	92-Up	76741G	K53874
741D	Valve Kit, Press Valve (OS) & Boost Valve (requires T-76948-TL4, T-76948-BST).....	1	91-95	76741PBK	K53875E
741D	Valve Kit, Press Valve (OS) & Boost Valve (requires T-76948-TL4, T-76948-BST).....	1	96-Up	76741PCK	K53875F
741D	Valve, Main Pressure Regulator (AODE) .....	1	92-Up	76741P-1	53975E
741D	Valve, Pressure Regulator w/ Annular Grooves (4R70W) .....	1	96-Up	76741PA-1	53975F
741D	Valve Kit, Pressure Regulator (AODE, 4R70W) (Steel) .....	1	92-Up	76741PRK	53975P
741D	Valve Kit, Pressure Regulator (Elevated) (4R70W).....	1	96-Up	76741PAK	K53975F
741D	Valve Kit, Pressure Regulator Boost (AOD) (Large Ratio).....	1	80-Up	76741FB	K53976D
741D	Valve Kit, Pressure Regulator Boost (AOD) (No O-Rings) .....	1	80-Up	76741FA	K53976B
741D	Valve Kit, Pressure Regulator Boost (AOD) (w/ O-Rings).....	1	80-Up	76741F	K53976
741D	Valve Kit, Pressure Regulator Boost (AODE, 4R70W) .....	1	92-Up	76741PK	K53976E
741D	Valve, Relief (Bag of 10).....	1	80-Up	76741A-1	67966
741D	Valve, Shift (Bore Sealing Tool) (AOD) .....	1	80-Up	T760	T-9139
741D	Valve Kit, Solenoid Reg Valve (requires T-76948-BST2) .....	1	92-Up	76741HK	K53882
741D	Valve Kit, TC Control Valve & Plunger (AOD) (requires T-76970-TL).....	1	80-93	76741NK	53977V
741D	Valve Kit, Throttle Valve w/ O-Rings (AOD) (Uses ORMK-3).....	1	80-93	76741BK	K53977D
<b>CASES &amp; HOUSINGS</b>					
760H	Case (AOD) (Small Cooler Line Fittings) 11/16" .....	1	80-93	76760	N/A
760H	Case (AOD) (Large Cooler Line Fittings) 3/4" .....	1	80-93	76760A	N/A
760H	Case (AODE) (3 Bolt Starter) (Large VB Pin Holes, 1.10" Wide Linkage) .....	1	92-Up	76760BB	N/A
760H	Case (AODE) (3 Bolt Starter) (Small VB Pin Holes, 1.10" Wide Linkage) .....	1	96-Up	76760D	N/A
765H	Pan (AODE) (4wd) .....	1	92-Up	76765B	N/A
770H	Extension Housing (2wd) (10 1/2" Long) (Small Seal) .....	1	80-92	76770	N/A
770H	Extension Housing (2wd) (10 1/2" Long) (Large Seal) .....	1	93-Up	76770C	N/A
770H	Extension Housing (2wd) (11 1/2" Long) (Small Seal) .....	1	80-92	76770A	N/A
770H	Extension Housing (2wd) (11 1/2" Long) (Large Seal) .....	1	93-Up	76770D	N/A
770H	Extension Housing (4wd) (w/ 2 Threaded Bosses For Shifter) .....	1	80-Up	76770B	N/A
774	Housing, Driven Speed-O (Cable Driven).....	1	80-93	36436	20A-412
774	Housing, Driven Speed-O (Electric).....	1	92-Up	86436A	20A-412A
843	Bracket, EPC Solenoid Bracket (AODE) .....	1	92-95	76843	53158A
843	Bracket, EPC Solenoid Bracket (AODE) .....	1	96-04	76843A	53158B
843	Bracket, EPC Solenoid Bracket (AODE) .....	1	05-Up	76843B	53158C
853F	Cushion, Forward Clutch (.074" Waved) 4R70W, 4R75W .....	1	96-Up	76853C	53420B
853F	Cushion, Forward Clutch (w/ Cast Iron Drum).....	1	80-Up	76853	53420
853F	Cushion, Forward Clutch (w/ Stamped Steel Drum) .....	1	89-98	76853B	53420A

**4R70W/4R75W  
4R70E/4R75E**

**FORD AOD (FIOD)  
AOD-E (ELECTRONIC)**

ILL.	DESCRIPTION	QTY.	YEAR	PART NO.	REFERENCE NO.
<b>SNAP RINGS</b>					
874E	Holds Intermediate Sprag Retainer to Reverse Drum .....	1	80-Up	76874	53962
874E	Holds Intermediate Sprag Retainer to Reverse Drum (Spiral) Update .....	1	80-Up	76874A	53962S
876B	Forward & Reverse Clutch .106" .....	1	80-Up	76876E	N/A
878G	Direct Clutch .052" .....	1	80-Up	76878EA	N/A
878G	Direct Clutch .066" .....	1	80-Up	76878EB	N/A
878G	Direct Clutch .080" .....	1	80-Up	76878EC	N/A
878G	Direct Clutch .094" .....	1	80-Up	76878ED	N/A
<b>MISCELLANEOUS COMPONENTS</b>					
900H	Servo Assembly, Overdrive (V-6) (w/ Letter A) (AOD) .....	1	80-93	76900B	N/A
902H	Piston, Overdrive Servo (Super Servo by Superior) (AOD) .....	1	93-98	A76902S	K53986S
902H	Piston, Overdrive Servo 2.680" OD (1 Piece w/ Molded Rubber) (AOE).....	1	92-Up	76902E	53528E
902H	Piston, Overdrive Servo 2.500"OD (2 Piece w/ Molded Rubber w/ Sleeve) (AOE) .....	1	93-Up	76902EA	53528F
903	Pin, Overdrive Servo (1 Pin, 2 O-Rings, 1 Washer) (AOD) .....	1	80-93	76903G	53707
903	Pin, Overdrive Servo (1 Pin, 2 O-Rings, 1 Washer) (AOE) .....	1	92-Up	76903	53707B
N.I.	O-Rings for 76903 & 76903G (Bag of 25) .....	1	80-Up	ORMK-1	N/A
912H	Piston, Low/ Reverse Servo (1-Groove) .....	1	80-Up	76912	53528
912H	Piston, Low/ Reverse Servo (2-Groove) .....	1	80-Up	76912A	53528A
912H	Piston, Low/ Reverse Servo (3-Groove) .....	1	80-Up	76912B	53528B
914H	Cover, Low/ Reverse Servo .....	1	80-Up	76914	53529
926	Spring Kit, 2-3 Accumulator (Designed not to Coil Bind) (Pkg of 3) .....	1	92-Up	A76926K	N/A
926	Spring, 1-2 Accumulator (Pink) .....	1	92-Up	76926A	N/A
926	Spring, 1-2 Accumulator (White) .....	1	92-Up	76926B	53706
926	Spring, 1-2 Accumulator (Purple) .....	1	92-Up	76926E	53706A
927	Piston, 1-2 Accumulator (Bonded Rubber) .....	1	94-Up	76927B	53986
927	Piston & Sleeve Kit, 1-2 Accumulator (AOE, 4R70W) (requires T-76890-TL).....	1	92-Up	76927K	K53987S
929	Cover, 1-2 Accumulator (Bonded Rubber) (AOE) .....	1	94-Up	76929A	53987
930	Accumulator Assembly, 2-3 Accumulator (AOD).....	1	80-93	76930	N/A
930	Accumulator Assembly, 2-3 Accumulator (AOE).....	1	92-Up	76930E	N/A
931	Spring Kit, 2-3 Accumulator (Designed not to Coil Bind) (Pkg of 3) .....	1	92-Up	A76926K	N/A
931	Spring, 2-3 Accumulator (Pink) (1.075" Wide) .....	1	92-Up	76926A	N/A
931	Spring, 2-3 Accumulator (White) (1.075" Wide) .....	1	92-Up	76926B	53706
931	Spring, 2-3 Accumulator (Purple) (1.075" Wide) .....	1	92-Up	76926E	53706A
931	Spring, 2-3 Accumulator (0.835" Wide) .....	1	92-Up	76931A	53709
932	Piston Kit, 2-3 Accumulator Piston & Sleeve (AOD, AOE) .....	1	80-Up	76932BK	K53985S
932	Piston, 2-3 Accumulator (AOD) .....	1	80-93	76932	K53985
932	Piston, 2-3 Accumulator (AOE) (Bonded Rubber) (Retros 83-Up) .....	1	92-Up	76932EA	53985R
936	Spring Kit, 3-4 Accumulator (Designed not to Coil Bind) (Pkg of 3) .....	1	92-Up	A76926K	N/A
936H	Spring, 3-4 Accumulator (Pink) .....	1	92-Up	76926A	N/A
936H	Spring, 3-4 Accumulator (White) .....	1	92-Up	76926B	53706
936H	Spring, 3-4 Accumulator (Purple) .....	1	92-Up	76926E	53706A
962A	Piston, Intermediate Clutch (Bonded) (4R70W, 4R75W) .....	1	04-Up	76962A	53531
966B	Piston, Reverse Clutch (For Stamped Steel Drum).....	1	90-Up	76966E	53964
975D	Retainer w/ Spring, Direct Clutch Return .....	1	80-Up	76975	53946
976B	Spring, Reverse Clutch Return .....	1	80-Up	76976	53419
996	Fitting, Cooler Push-In 20mm 3/8" Line (Teckpak).....	1	80-Up	T56996	96-208B
996	Fitting, Cooler Push-In 18mm 5/16" Line (Teckpak).....	1	80-Up	T76996	96-208
Tool	Air Test Plate (AOD) .....	1	80-Up	T-1617	T-1617
Tool	Air Test Plate (AOE) .....	1	80-Up	T-1617-A	T-1617-A
Tool	Boring Tool (AOD) (Case) Governor Bore/ (AOE, 4R70W) Output Shaft Bore Repair .	1	80-Up	T-1695	T-1695
Tool	Bore Repair Sleeve, Case (2.00" Long) (AOD) (requires T-1695) .....	1	80-Up	T-1695-SL	T-1695-SL
Tool	Bore Repair Sleeve, Case (1.50" Long) (AOE, 4R70W) (requires T-1695) .....	1	80-Up	T-1695-SLE	T-1690-SLE
Tool	Cooler And Fuel Line Disconnect Tool .....	1	80-Up	T-1890	T-1890
Tool	Lip Seal Installer / Protector Kit.....	1	80-Up	T-1600-K	T-1600K
Tool	PNP Remover / Installer.....	1	80-Up	T-0432	T-0432
Tool	Shift Linkage Removal / Installer Tool.....	1	80-Up	T-0445	T-0445
Tool	Throttle Valve Cable Gauge .....	1	80-Up	T-1601	T-1601

AOD/AOD-E