

## U340E AND U441E AUTOMATIC TRANSAXLES

### DESCRIPTION

- The new model uses 2 types (U340E, U441E) of automatic transaxle.
- A U340E automatic transaxle is provided on the 1NZ-FE engine model, and a U441E automatic transaxle is provided on the 2NZ-FE engine model.
- A low-viscosity type automatic transmission fluid (Toyota Genuine ATF WS) is used for the U340E automatic transaxle.
- Shift control in uphill/downhill traveling is used for the automatic transaxles.
- The basic construction of the automatic transaxles is the same as on the previous model.

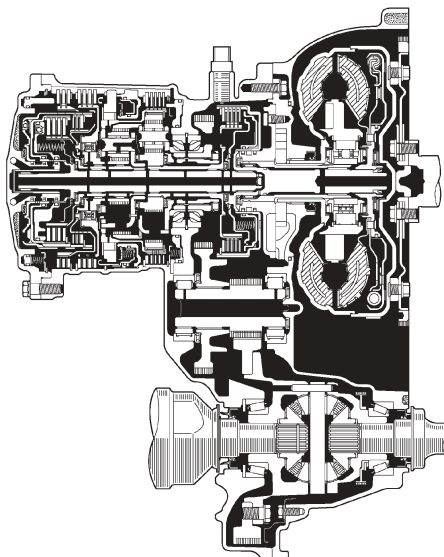

171CH03

U340E Automatic Transaxle

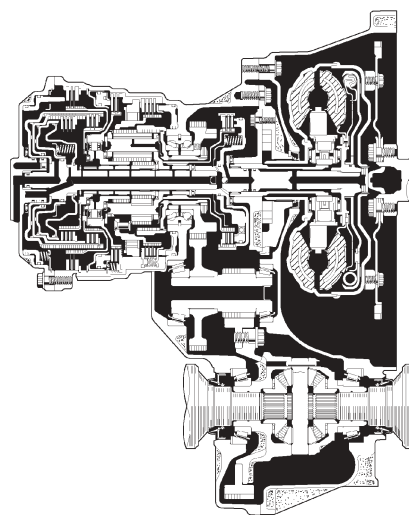

165CH23

U441E Automatic Transaxle

CH

### ► Specification ◀

Transaxle Type		U340E	U441E
Engine Type		1NZ-FE	2NZ-FE
Gear Ratio	1st	2.847	2.875
	2nd	1.552	1.568
	3rd	1.000	←
	4th	0.700	0.696
	Reverse	2.343	2.300
Differential Gear Ratio* <sup>1</sup>		4.237	4.375
Fluid Capacity* <sup>2</sup> Liters (US qts, Imp.qts)		6.4 (6.78, 5.63)	5.6 (5.96, 4.96)
Fluid Type		Toyota Genuine ATF WS	Toyota Genuine ATF Type T-IV
Weight (Reference)* <sup>3</sup> kg (lb)		68.5 (150.7)	56.7 (124.7)

\*<sup>1</sup>: Counter Gear Ratio Included

\*<sup>2</sup>: Differential Included

\*<sup>3</sup>: Weight shows the figure with the fluid fully filled.

**TORQUE CONVERTER**

- This torque converter has optimally designed fluid passages and impeller configuration resulting in substantially enhanced transmission efficiency to ensure good starting, acceleration and fuel economy.
- Furthermore, a hydraulically operated lock-up mechanism which cuts power transmission losses due to slippage at medium and high speeds is used.

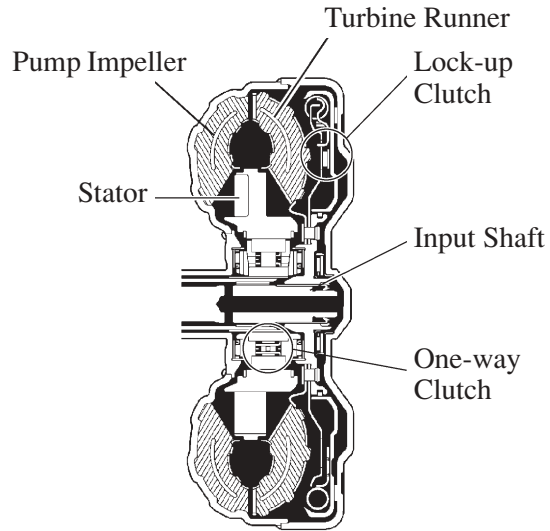

216CH06

► Specifications ◀

Automatic Transaxle Type	U340E	U441E
Torque Converter Type	3-Element, 1-Step, 2-Phase (With Lock-up Mechanism)	←
Stall Torque Ratio	1.95	2.00

**OIL PUMP**

The oil pump is combined with torque converter, lubricates the planetary gear units and supplies operating pressure to the hydraulic control.

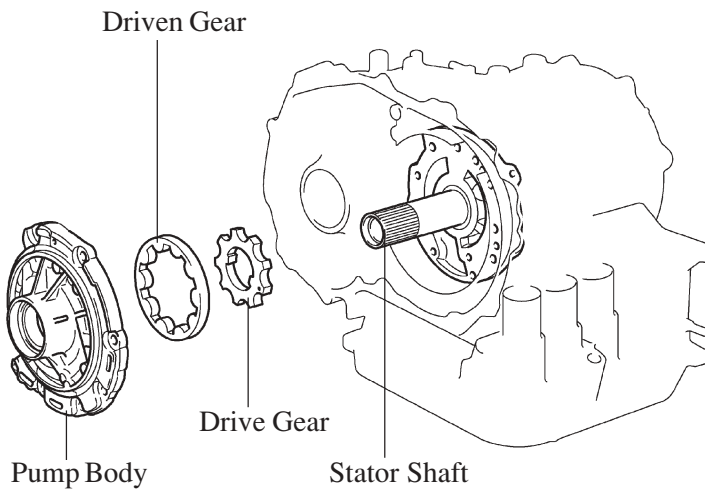

247CH20

## ■ ATF (AUTOMATIC TRANSMISSION FLUID) WS

- ATF WS is used in the U340E automatic transaxle.
- The ATF WS is used to reduce the resistance of the ATF and ensure fuel economy by reducing its viscosity in the practical operation range. At the high-temperature end, its viscosity is the same as that of the ATF Type T-IV, which ensures the durability of the automatic transaxle.
- There is no interchangeability between the ATF WS and other types of ATFs (ATF Type T-IV, D-II).

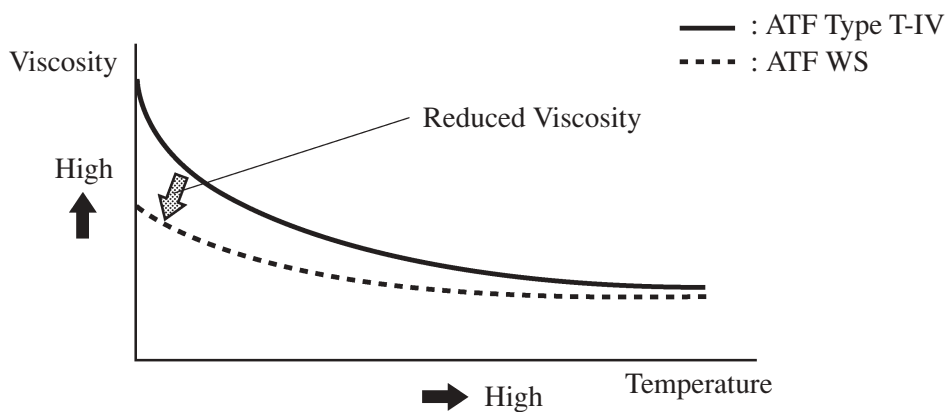

259LSK03

CH

### Service Tip

- The color of the ATF level gauge used in the ATF WS has been changed to black. (Orange was used in the ATF Type T-IV on the previous model.)
- If a vehicle with a transaxle filled with ATF WS is replenished with another type of ATF, the vehicle might not start off at extremely low temperatures.

## PLANETARY GEAR UNIT

### 1. U340E Automatic Transaxle

#### General

- A CR-CR type planetary gear is used in the planetary gear unit which is located on the input shaft. This planetary gear is a type of the planetary gear unit that joins the front and rear planetary carriers to the front and rear ring gears. As result, the unit has been made significantly simple and compact.
- A centrifugal fluid pressure canceling mechanism is used in the C<sub>1</sub> clutch which is applied when shifting from 3rd to 4th.

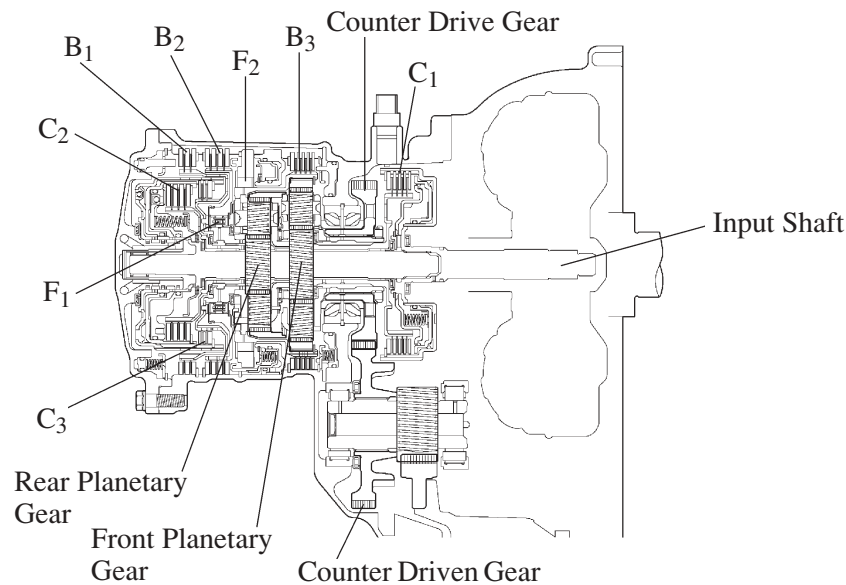

216CH05

#### ► Specification ◀

C <sub>1</sub>	Forward Clutch	The No. of Discs	4
C <sub>2</sub>	Direct Clutch		3
C <sub>3</sub>	Reverse Clutch		2
B <sub>1</sub>	OD & 2nd Brake		2
B <sub>2</sub>	2nd Brake		3
B <sub>3</sub>	1st & Reverse Brake		4
F <sub>1</sub>	No. 1 One-Way Clutch	The No. of Sprags	16
F <sub>2</sub>	No. 2 One-Way Clutch	The No. of Rollers	15
Front Planetary Gear		The No. of Sun Gear Teeth	46
		The No. of Pinion Gear Teeth	21
		The No. of Ring Gear Teeth	85
Rear Planetary Gear		The No. of Sun Gear Teeth	32
		The No. of Pinion Gear Teeth	21
		The No. of Ring Gear Teeth	75
Counter Gear		The No. of Drive Gear Teeth	52
		The No. of Driven Gear Teeth	53

**Function of Components**

Component		Function
C <sub>1</sub>	Forward Clutch	Connects input shaft and front planetary sun gear.
C <sub>2</sub>	Direct Clutch	Connects intermediate shaft and rear planetary carrier.
C <sub>3</sub>	Reverse Clutch	Connects intermediate shaft and rear planetary sun gear.
B <sub>1</sub>	OD & 2nd Brake	Locks the rear planetary sun gear.
B <sub>2</sub>	2nd Brake	Prevents rear planetary sun gear from turning counterclockwise.
B <sub>3</sub>	1st & Reverse Brake	Locks the front planetary ring gear and rear planetary carrier.
F <sub>1</sub>	No. 1 One-Way Clutch	Prevents rear planetary sun gear from turning counterclockwise.
F <sub>2</sub>	No. 2 One-Way Clutch	Prevents front planetary ring gear and rear planetary carrier from turning counterclockwise.
Planetary Gears		These gears change the route through which driving force is transmitted, in accordance with the operation of each clutch and brake, in order to increase or reduce the input and output speed.

**CH****Motive Power Transaxle**

Shift Lever Position	Gear	Solenoid Valve		Clutch			Brake			One-Way Clutch	
		S1	S2	C <sub>1</sub>	C <sub>2</sub>	C <sub>3</sub>	B <sub>1</sub>	B <sub>2</sub>	B <sub>3</sub>	F <sub>1</sub>	F <sub>2</sub>
P	Park	ON	ON								
R	Reverse	ON	ON			○			○		
N	Neutral	ON	ON								
D	1st	ON	ON	○							○
	2nd	ON	OFF	○				○		○	
	3rd	OFF	OFF	○	○			○			
	4th	OFF	ON		○		○	○			
3	1st	ON	ON	○							○
	2nd	ON	OFF	○				○		○	
	3rd	OFF	OFF	○	○			○			
2	1st	ON	ON	○							○
	2nd	ON	OFF	○			○	○		○	
L	1st	ON	ON	○					○		○

1st Gear (D, 3 or 2 Position)

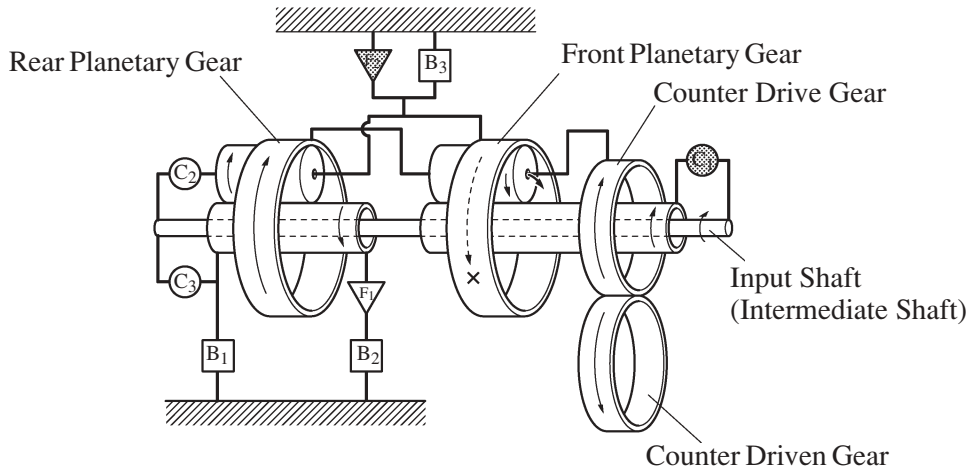

248CH39

2nd Gear (D or 3 Position)

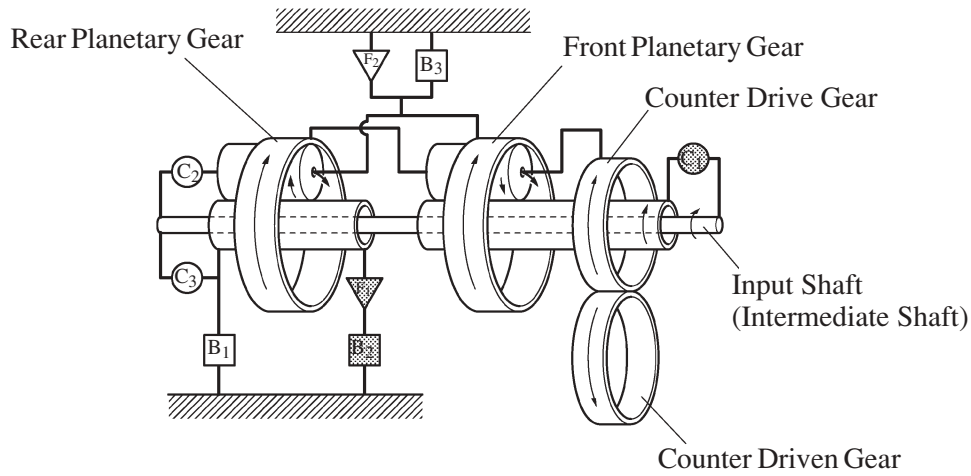

171CH06

3rd Gear (D or 3 Position)

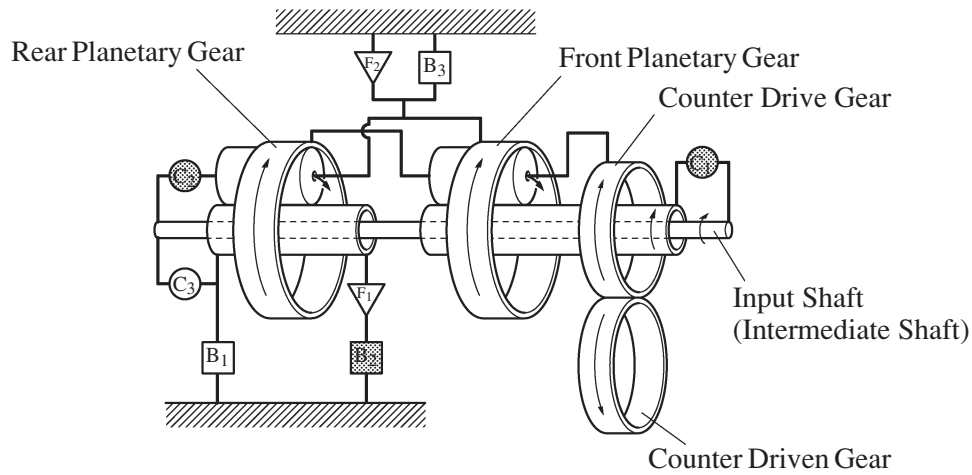

248CH40

**4th Gear (D Position)**

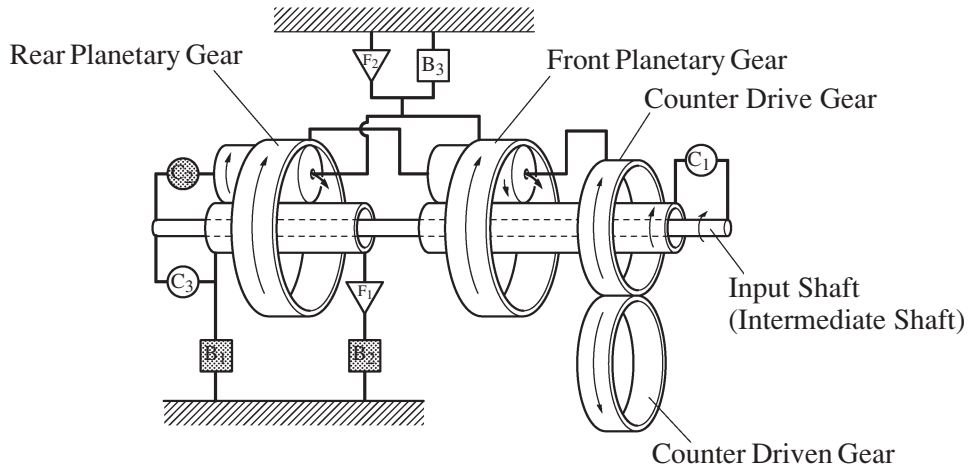

248CH41

**CH**

**2nd Gear (2 Position)**

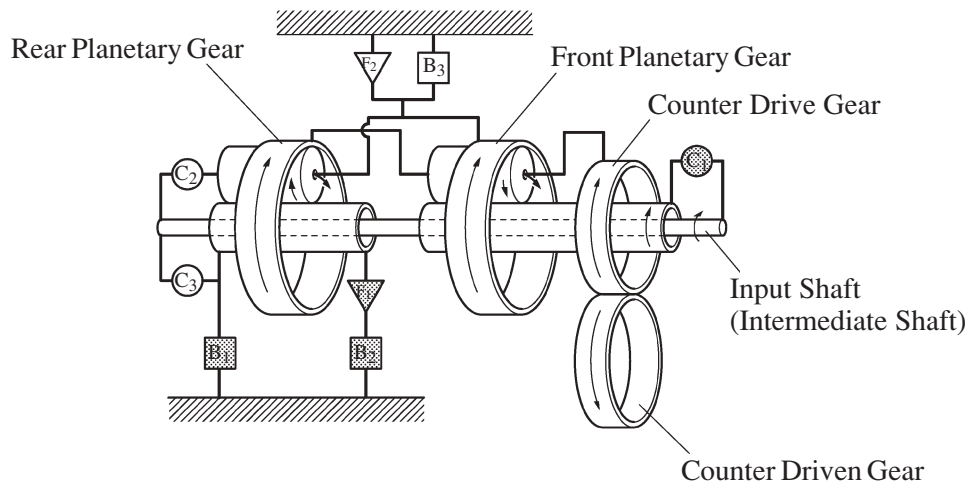

171CH09

**1st Gear (L Position)**

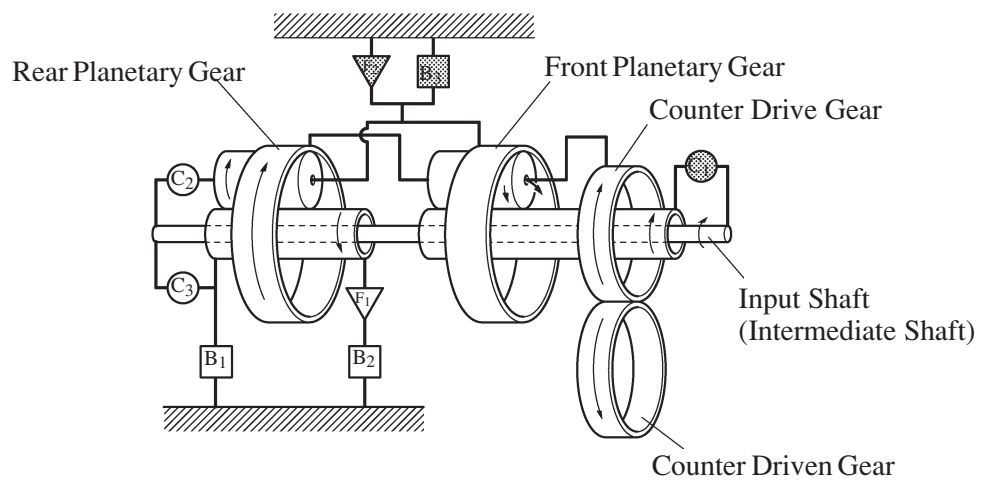

248CH42

Reverse Gear (R Position)

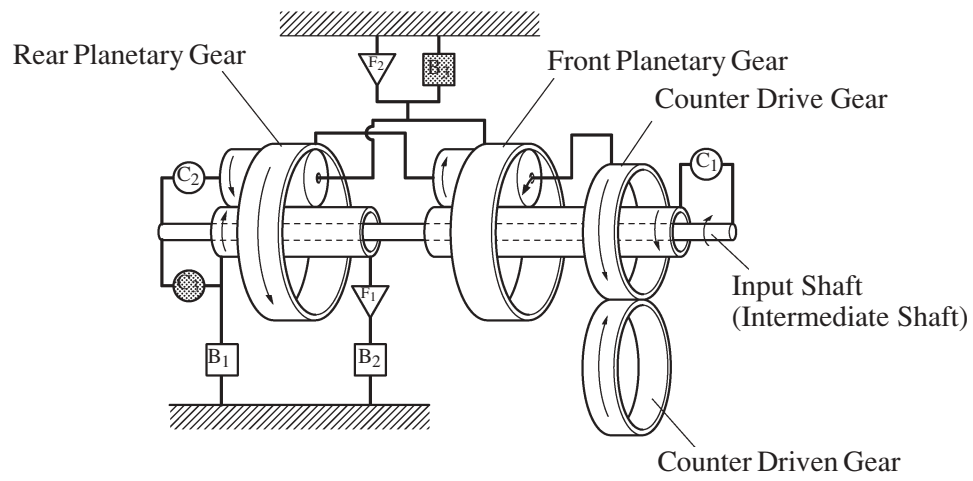



## 2. U441E Automatic Transaxle

### General

- A Ravigneaux type planetary gear is used in the planetary gear unit which is located on the input shaft. This planetary gear combines a set of sun gears with two different diameters and a short pinion gear and long pinion gear.
- A centrifugal fluid pressure canceling mechanism is used in the C<sub>1</sub> clutch, which is applied when shifting from the 4th to 3rd and from the 4th to 2nd.

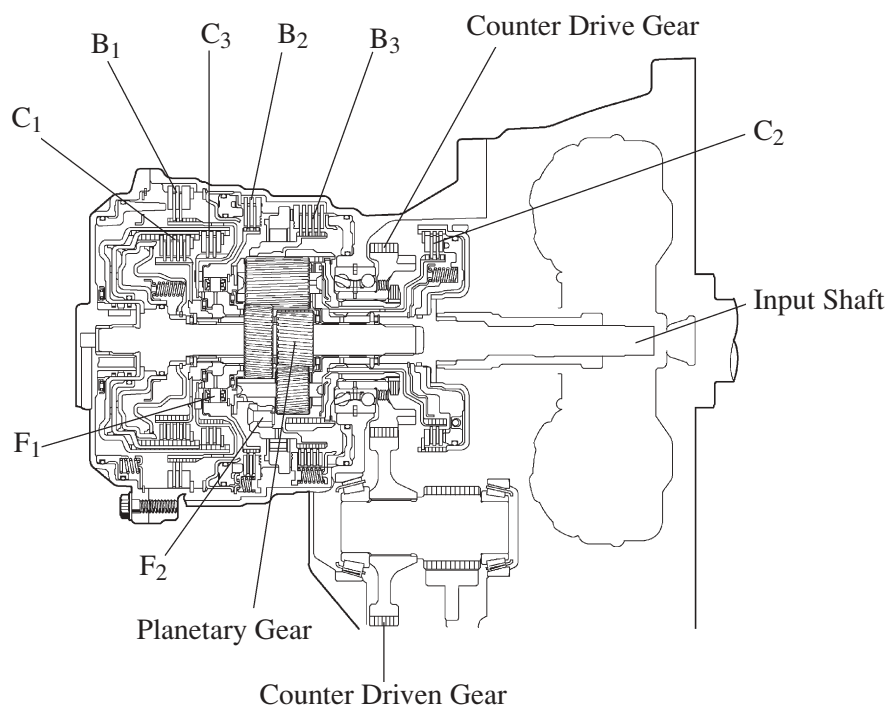

00SCH33Y

### ► Specification ◀

C <sub>1</sub>	Forward Clutch	The No. of Discs	4
C <sub>2</sub>	Direct Clutch		2
C <sub>3</sub>	Reverse Clutch		2
B <sub>1</sub>	OD & 2nd Brake		2
B <sub>2</sub>	2nd Brake		2
B <sub>3</sub>	1st & Reverse Brake		4
F <sub>1</sub>	No. 1 One-Way Clutch	The No. of Sprags	12
F <sub>2</sub>	No. 2 One-Way Clutch	The No. of Rollers	15
Planetary Gear	The No. of No. 1 Sun Gear Teeth		24
	The No. of No. 2 Sun Gear Teeth		30
	The No. of Long Pinion Gear Teeth		20
	The No. of Short Pinion Gear Teeth		19
	The No. of Ring Gear Teeth		69
Counter Gear	The No. of Drive Gear Teeth		44
	The No. of Driven Gear Teeth		45

**Function of Components**

Component		Function
C <sub>1</sub>	Forward Clutch	Connects input shaft and planetary sun gear No. 1.
C <sub>2</sub>	Direct Clutch	Connects input shaft and planetary carrier.
C <sub>3</sub>	Reverse Clutch	Connects input shaft and planetary sun gear No. 2.
B <sub>1</sub>	OD & 2nd Brake	Locks the planetary sun gear No. 2.
B <sub>2</sub>	2nd Brake	Prevents planetary sun gear No. 2 from turning counterclockwise.
B <sub>3</sub>	1st & Reverse Brake	Locks the planetary carrier.
F <sub>1</sub>	No. 1 One-Way Clutch	Prevents planetary sun gear No. 2 from turning counterclockwise.
F <sub>2</sub>	No. 2 One-Way Clutch	Prevents planetary carrier from turning counterclockwise.
Planetary Gears		These gears change the route through which driving force is transmitted, in accordance with the operation of each clutch and brake, in order to increase or reduce the input and output speed.

**Motive Power Transaxle**

Shift Lever Position	Gear	Solenoid Valve		Clutch			Brake			One-Way Clutch	
		S1	S2	C <sub>1</sub>	C <sub>2</sub>	C <sub>3</sub>	B <sub>1</sub>	B <sub>2</sub>	B <sub>3</sub>	F <sub>1</sub>	F <sub>2</sub>
P	Park	ON	ON								
R	Reverse	ON	ON			○			○		
N	Neutral	ON	ON								
D	1st	ON	ON	○							○
	2nd	ON	OFF	○				○		○	
	3rd	OFF	OFF	○	○			○			
	4th	OFF	ON		○		○	○			
3	1st	ON	ON	○							○
	2nd	ON	OFF	○				○		○	
	3rd	OFF	OFF	○	○			○			
2	1st	ON	ON	○							○
	2nd	ON	OFF	○			○	○		○	
L	1st	ON	ON	○					○		○





Reverse Gear (R Position)

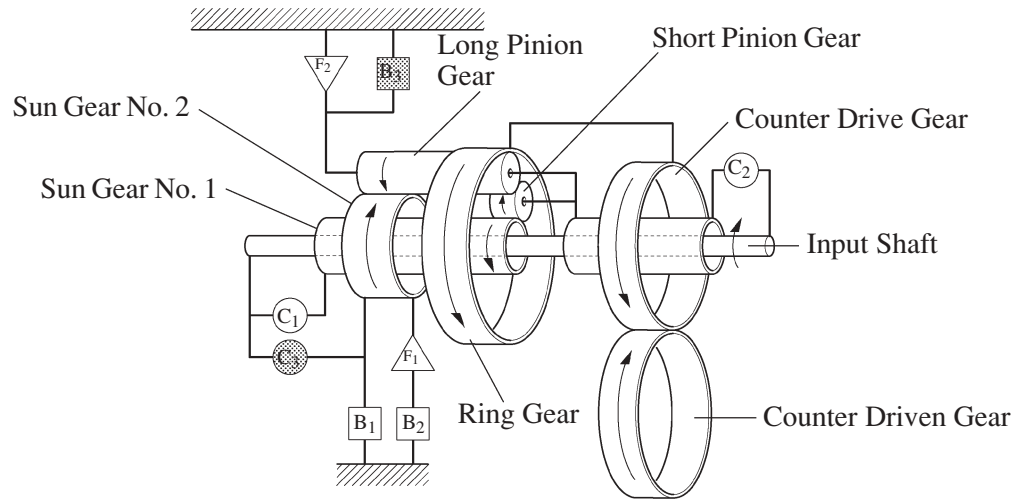

165CH41

### 3. Centrifugal Fluid Pressure Canceling Mechanism

There are two reasons for improving the conventional clutch mechanism:

- To prevent the generation of pressure by the centrifugal force that applied to the fluid in piston fluid pressure chamber (hereafter referred to as “chamber A”) when the clutch is released, a check ball is provided to discharge the fluid. Therefore, before the clutch can be subsequently applied, it took time for the fluid to fill the chamber A.
- During shifting, in addition to the original clutch pressure that is controlled by the valve body, the pressure that acts on the fluid in the chamber A also exerts influence, which is dependent upon revolution fluctuations.

To address these two needs for improvement, a canceling fluid pressure chamber (hereafter referred to as “chamber B”) has been provided opposite chamber A.

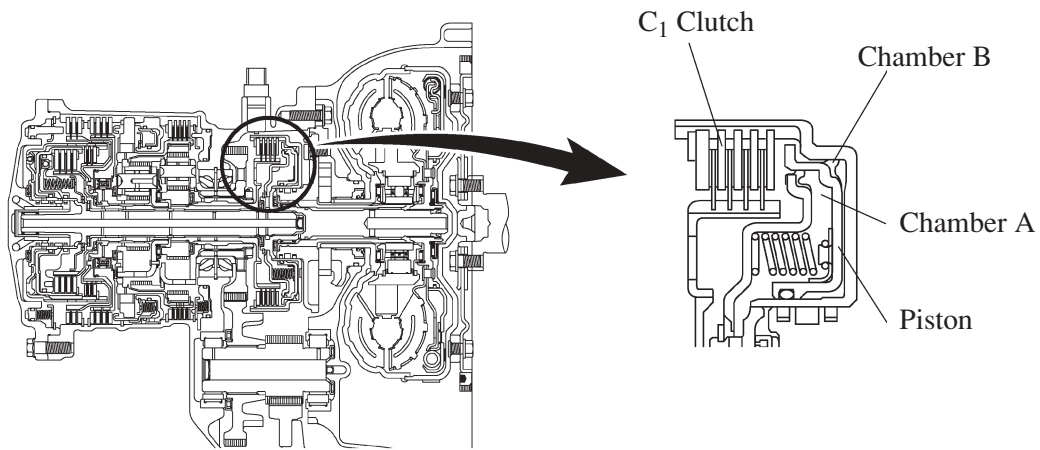

U340E Automatic Transaxle

247CH21

By utilizing the lubrication fluid such as that of the shaft, the same amount of centrifugal force is applied, thus canceling the centrifugal force that is applied to the piston itself. Accordingly, it is not necessary to discharge the fluid through the use of a check ball, and a highly responsive and smooth shifting characteristic has been achieved.

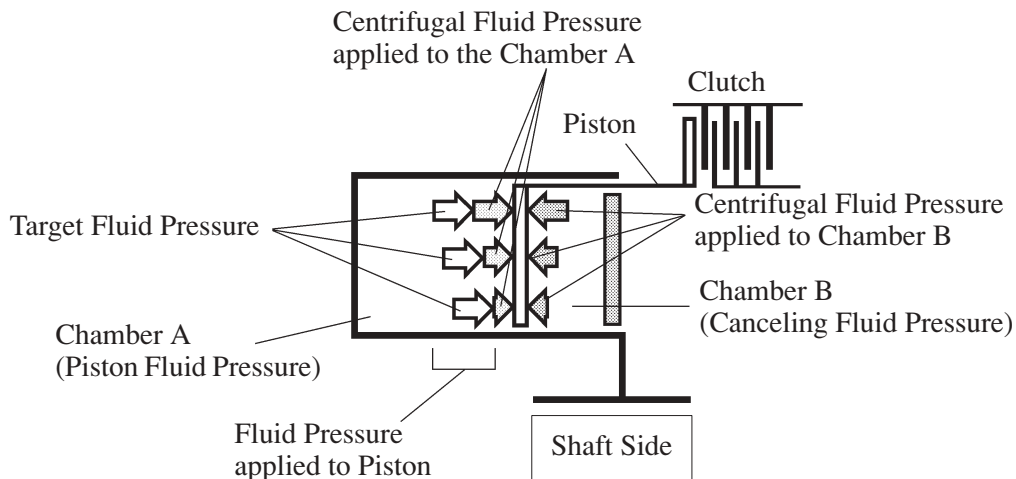

157CH17

Fluid pressure applied to piston	–	Centrifugal fluid pressure applied to chamber B	=	Target fluid pressure (original clutch pressure)
----------------------------------	---	---	---	--

■ VALVE BODY UNIT

1. General

The valve body consists of the upper and lower valve bodies and 5 solenoid valves. The 5 solenoid valves are installed in the lower valve body for serviceability.

► U340E Valve Body ◀

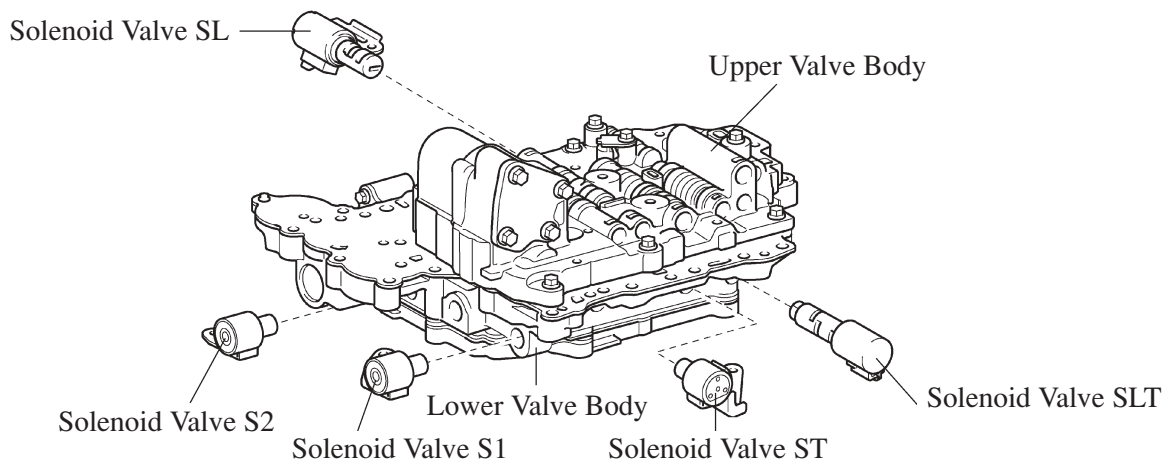

00SCH98Y

► U441E Valve Body ◀

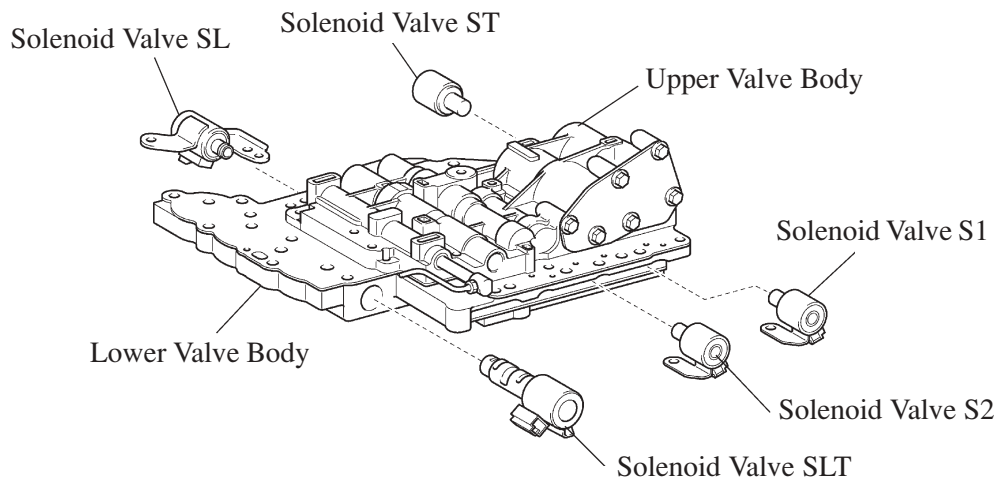

00SCH34Y

2. Function of Solenoid Valve

Solenoid Valve	Action	Function
S1	For 2-3 shift valve control	Shifts gears by switching the 2-3 shift valve and controlling the C <sub>2</sub> clutch.
S2	For 1-2 and 3-4 shift valve control	Shifts gears by switching the 1-2 and 3-4 shift valves and controlling 2 clutches (C <sub>1</sub> and C <sub>2</sub> ) and 2 brakes (B <sub>1</sub> and B <sub>2</sub> ).
ST	For clutch to clutch pressure control	Switches 3-4 and 4-3 shift valves.
SL	For clutch engagement pressure control	Controls the lock-up clutch.
SLT	For line pressure control	Controls the line pressure, secondary pressure, and accumulator back pressure.

## ■ ELECTRONIC CONTROL SYSTEM

### 1. General

The electronic control system of the U340E and U441E automatic transaxles consists of the controls listed below.

System	Function
Clutch to Clutch Pressure Control (See page CH-60)	<ul style="list-style-type: none"> <li>Controls the pressure that is applied directly to B<sub>1</sub> brake and C<sub>1</sub> clutch by actuating the solenoid valves (ST, SLT) in accordance with engine ECU signals.</li> <li>The solenoid valves minutely control the clutch pressure in accordance with the engine output and driving conditions.</li> </ul>
Clutch Pressure Optimal Control (See page CH-60)	The solenoid valve SLT minutely controls the clutch pressure in accordance with the engine output and driving conditions.
Line Pressure Control (See page CH-61)	Actuates the solenoid valve SLT to control the line pressure in accordance with information from the engine ECU and the operating conditions of the transaxle.
Shift Control in Uphill/Downhill Traveling (See page CH-62)	Controls to restrict the 4th upshift or to provide appropriate engine braking by using the engine ECU to determine whether the vehicle is traveling uphill or downhill.
High Response Shift Control (See page CH-61)	The shift time lag has been reduced to half by the centrifugal fluid pressure canceling mechanism and clutch pressure optimal control.
Shift Timing Control	The engine ECU sends current to the solenoid valve S1 and/or S2 based on the signals from each sensor and shifts the gear.
Lock-up Timing Control	The engine ECU sends current to the solenoid valve SL based on signals from each sensor and engages or disengages the lock-up clutch.
Engine Torque Control	Temporarily retards the engine ignition timing to restrict the output torque, thus ensuring the shift feel during up or down shifting.
“N” to “D” Squat Control	When the shift lever is shifted from the “N” to “D” position, the gear is temporarily shifted to the 3rd and then to the 1st to reduce vehicle squat.
Diagnosis (See page CH-63)	When the engine ECU detects a malfunction, the engine ECU makes a diagnosis and memorizes the failed section.
Fail-Safe (See Page CH-63)	Even if a malfunction is detected in the sensors or solenoids, the engine ECU effects fail-safe control to prevent the vehicle’s drivability from being affected significantly.



**2. Construction**

The configuration of the electronic control system in the U340E and U441E automatic transaxles is as shown in the following chart.

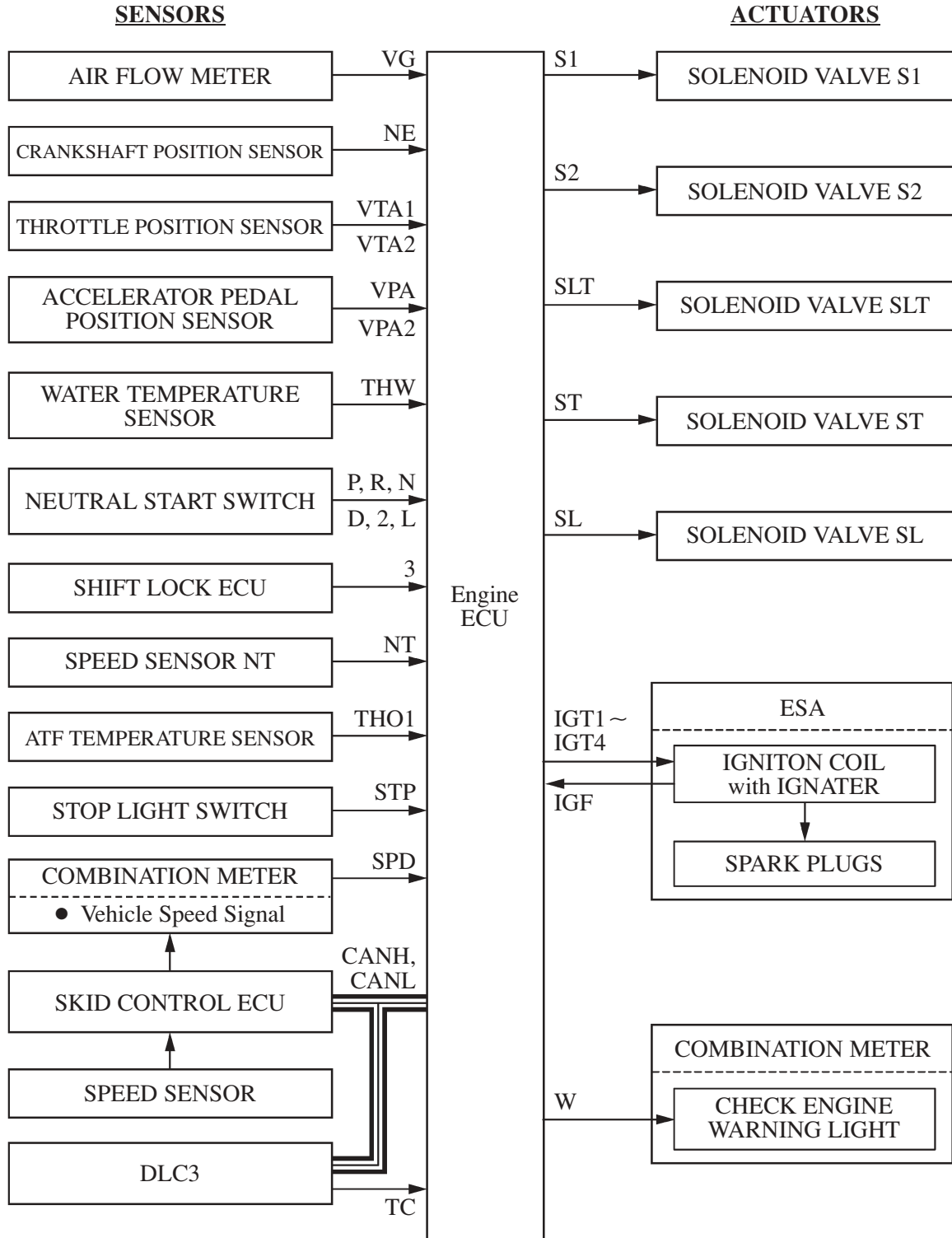

**CH**

### 3. Layout of Main Components

Check Engine Warning Light

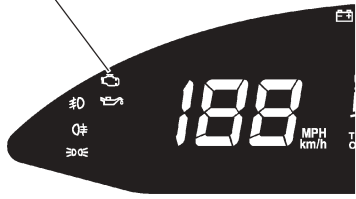

Engine ECU

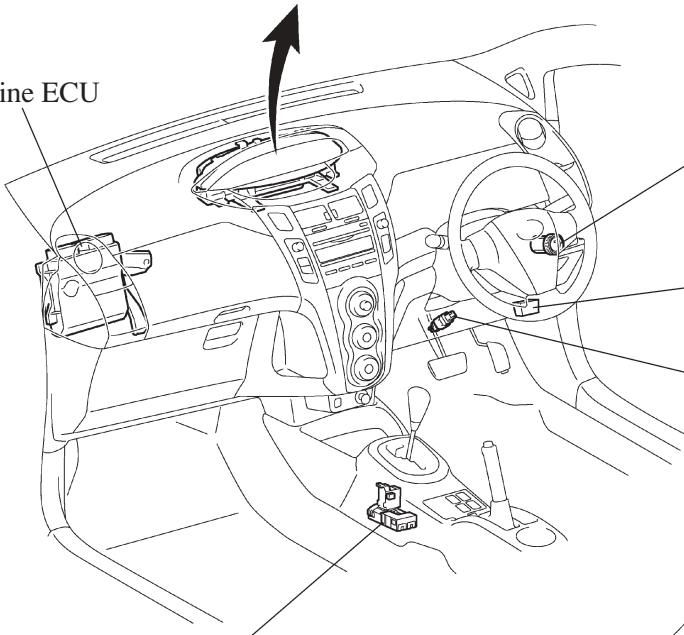

Ignition Switch  
● Key Interlock Solenoid

DLC3

Stop Light Switch

Shift Lock ECU  
● P Detection Switch  
● 3 Range Position Switch

Solenoid Valve SL

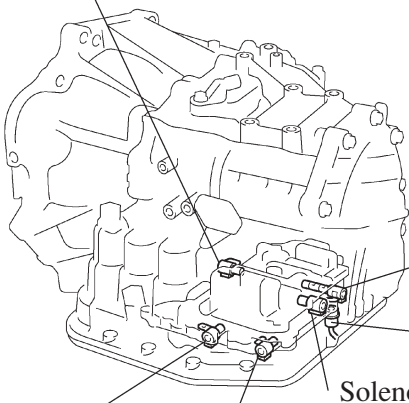

Solenoid Valve S2

Solenoid Valve S1

Solenoid Valve SLT

Speed Sensor NT

Neutral Start Switch

ATF Temperature Sensor

Solenoid Valve ST

### U340E Automatic Transaxle

## 4. Construction and Operation of Main Components

### ATF Temperature Sensor

- The ATF temperature sensor is installed in the lower valve body for direct detection of the fluid temperature.
- The ATF temperature sensor is used for correction of clutch and brake pressures to keep smooth shift quality every time.

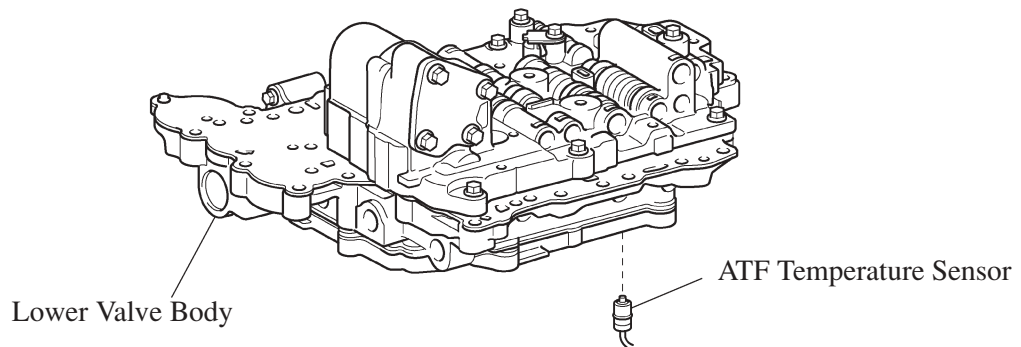

U340E Automatic Transaxle

247CH24

CH

### Speed Sensor NT

The speed sensor NT detects the input speed of the transaxle. The forward clutch ( $C_1$ ) drum is used as the timing rotor for this sensor.

Thus, the engine ECU can detect shift timing of the gears and appropriately control the engine torque and hydraulic pressure in response to the various conditions.

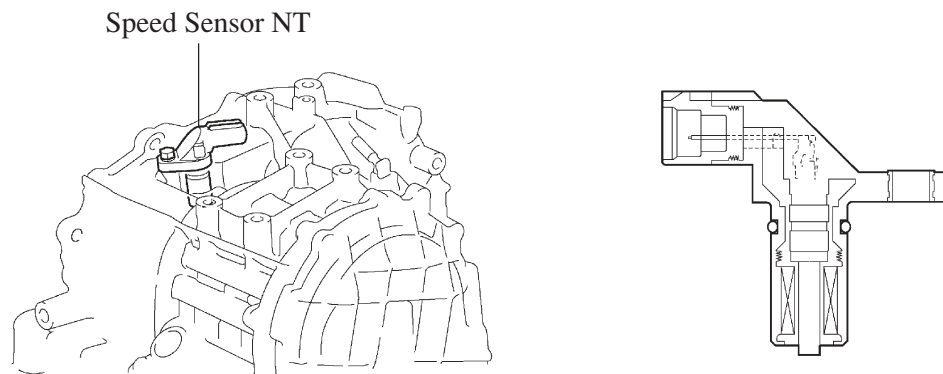

U340E Automatic Transaxle

Speed Sensor NT

216CH12

## 5. Clutch Pressure Control

### Clutch to Clutch Pressure Control

This control is used for shifting from the 3rd to 4th gear, and from the 4th to 3rd gear. It actuates solenoid valves ST and SLT in accordance with the signals from the engine ECU, and guides this output pressure directly to 4-3 shift timing valve and 3-4 shift timing valve in order to regulate the line pressure that acts on the B<sub>1</sub> brake and C<sub>1</sub> clutch.

As a result, compact B<sub>1</sub> and C<sub>1</sub> accumulators without a back pressure chamber have been realized.

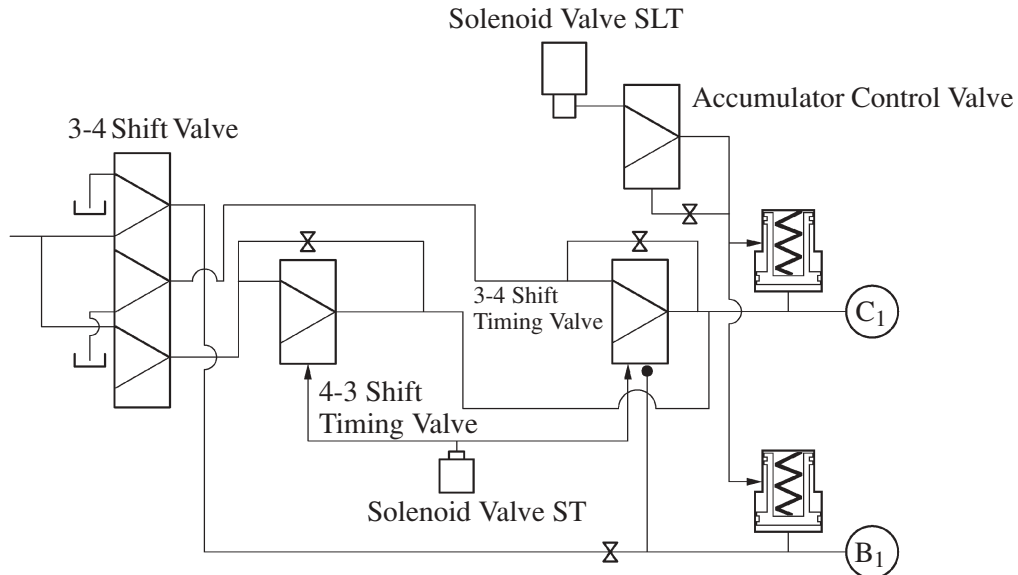

247CH25

### Clutch Pressure Optimal Control

The engine ECU monitors the signals from various types of sensors such as the speed sensor NT, allowing solenoid valve SLT to minutely control the clutch pressure in accordance with engine output and driving conditions. As a result, smooth shift characteristics have been realized.

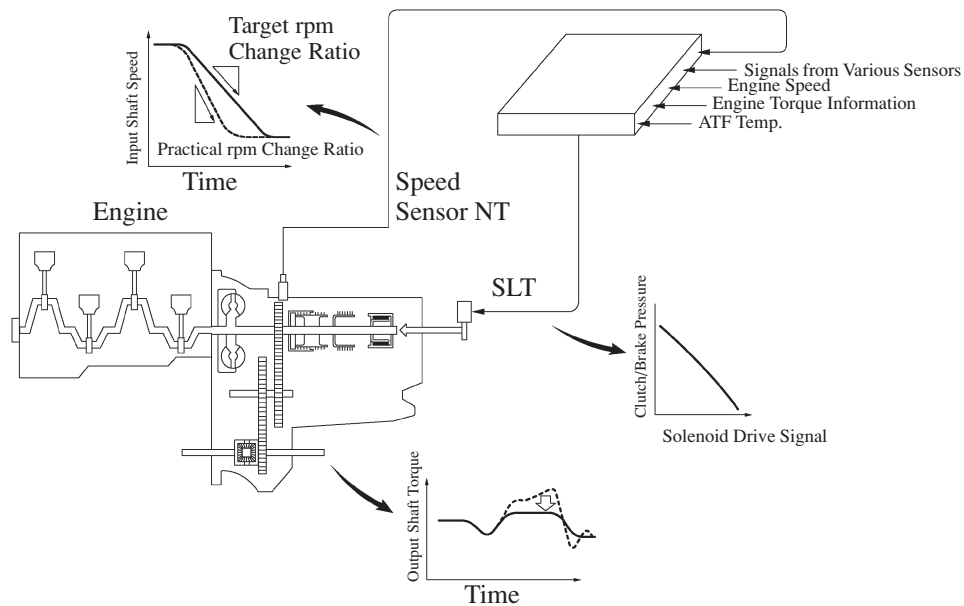

247CH26

## 6. Line Pressure Control

Through the use of the solenoid valve SLT, the line pressure is optimally controlled in accordance with the engine torque information, as well as with the internal operating conditions of the torque converter and the transaxle.

Accordingly, the line pressure can be controlled minutely in accordance with the engine output, traveling condition, and the ATF temperature, thus realizing smooth shift characteristics and optimizing the workload in the oil pump.

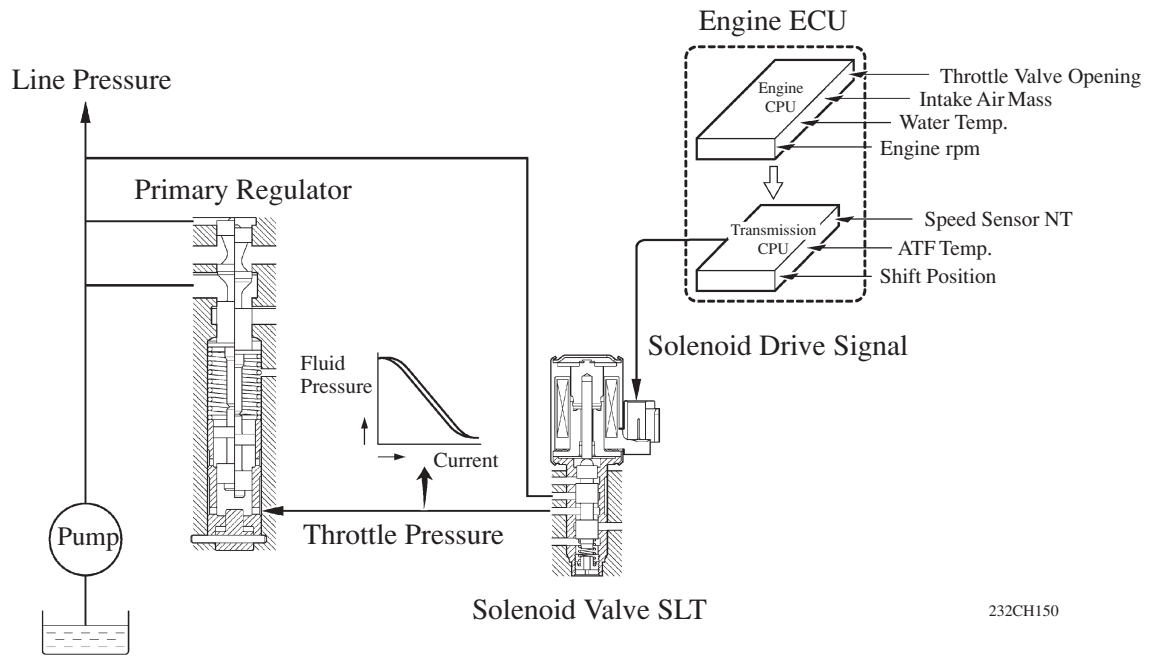

## 7. High Response Shift Control

Due to the use of the previously mentioned centrifugal fluid pressure canceling mechanism and the clutch pressure optimal control, not only smooth shifting has been achieved, but the shift time lag has been halved to realize excellent response.

## 8. Shift Control in Uphill/Downhill Traveling

### General

This control helps minimize the gear shifting when the driver operates the accelerator pedal while driving on a winding uphill or downhill road in order to ensure a smooth drive.

### Shift Control in Uphill Traveling

When the engine ECU detects uphill travel, it prohibits upshifting to the 4th after downshifting to the 3rd.

### Shift Control in Downhill Traveling

If a signal indicating that the driver has operated the brake pedal is input while the engine ECU detects downhill travel, it downshifts from the 4th to 3rd.

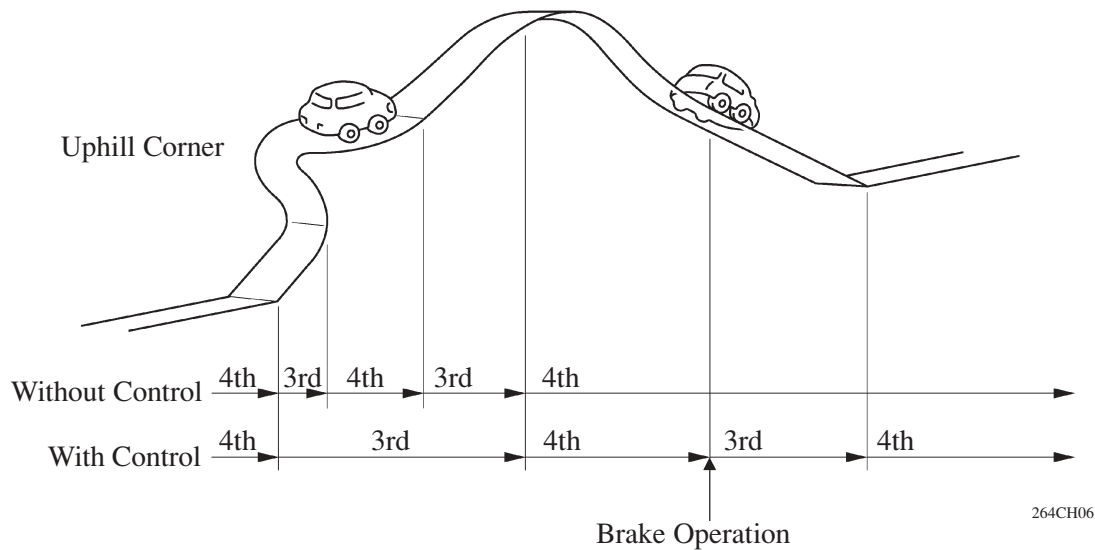

264CH06

### Uphill/Downhill Judgment

The actual acceleration calculated from the speed sensor signal is compared with the reference acceleration (based on level road travel) stored in the engine ECU to determine uphill or downhill travel.

Actual Acceleration < Reference Acceleration

Actual Acceleration > Reference Acceleration

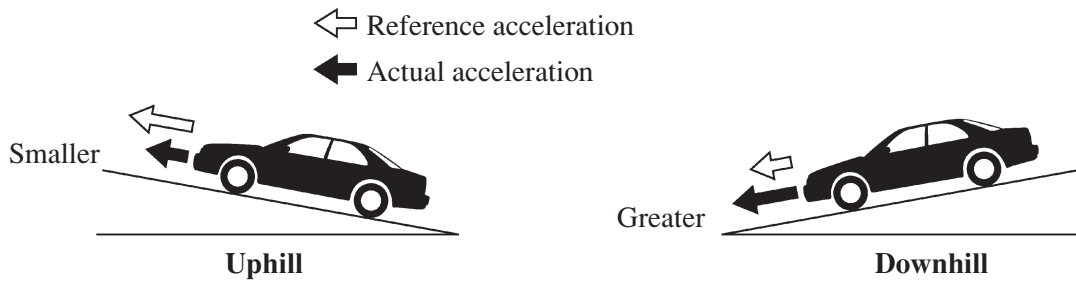

162CH10

## 9. Diagnosis

- When the engine ECU detects a malfunction, the engine ECU makes a diagnosis and memorizes the failed section. Furthermore, the check engine warning light in the combination meter illuminates or blinks to inform the driver.
- At the same time, the DTCs (Diagnosis Trouble Codes) are stored in memory. The DTCs can be read by connecting an intelligent tester II. For details, see the Yaris Repair Manual (Pub. No. RM00S0E).

## 10. Fail-Safe

This function minimizes the loss of operability when any abnormality occurs in each sensor or solenoid.

### ► Fail-Safe Control List ◀

Malfunction Part	Function
Vehicle Speed Signal	During a vehicle speed signal malfunction, the 4th upshift is prohibited.
Speed Sensor NT	During a speed sensor NT signal malfunction, the 4th upshift is prohibited.
ATF Temperature Sensor	During a ATF temperature sensor malfunction, the 4th upshift is prohibited.
Solenoid Valve SLT or SL	During a solenoid valves SLT or SL malfunction, the 4th upshift is prohibited.
Water Temperature Sensor, Knock Sensor, or Throttle Position Sensor	During a water temperature sensor, knock sensor, or throttle position sensor malfunction, the 4th upshift is prohibited.
Solenoid Valve S1 or S2	During a malfunction in the solenoid valve S1 or S2, the current to the faulty solenoid valve is cut off and control is effected by operating the normal solenoid valves. Shift control is effected as described in the table below, depending on the failed solenoid valve.

When all solenoid valve are normal			When solenoid valve S1 is abnormal			When solenoid valve S2 is abnormal			When solenoid valves S1 and S2 are abnormal		
Solenoid valve		Gear	Solenoid valve		Gear	Solenoid valve		Gear	Solenoid valve		Gear
S1	S2		S1	S2		S1	S2		S1	S2	
ON	ON	1st	x	ON ↓ OFF	3rd	ON	x	2nd	x	x	3rd
ON	OFF	2nd	x	OFF	3rd	ON	x	2nd	x	x	3rd
OFF	OFF	3rd	x	OFF	3rd	OFF	x	3rd	x	x	3rd
OFF	ON	4th	x	ON	4th	OFF	x	3rd	x	x	3rd

## ■ SHIFT CONTROL MECHANISM

### 1. General

- A gate type shift lever that uses a shift control cable is used. For the gate type, the shift lever button and the overdrive switch of the straight type shift lever have been discontinued. Similar functions are achieved through a single-shift operation (fore-aft and side-to-side).
- A shift lock system that consisting of the key interlock device and shift lock mechanism is used.

### 2. Shift Lock System

#### General

- The key interlock device prevents the key from being pulled out after the ignition switch is turned OFF, unless the shift lever is moved to the P position. Thus, the driver is urged to park the vehicle in the P position.
- The shift lock mechanism prevents the shift lever from being shifted to a position other than the P position, unless the ignition switch is ON and the brake pedal is depressed. It prevents the vehicle from starting off suddenly.

#### Layout of Main Components

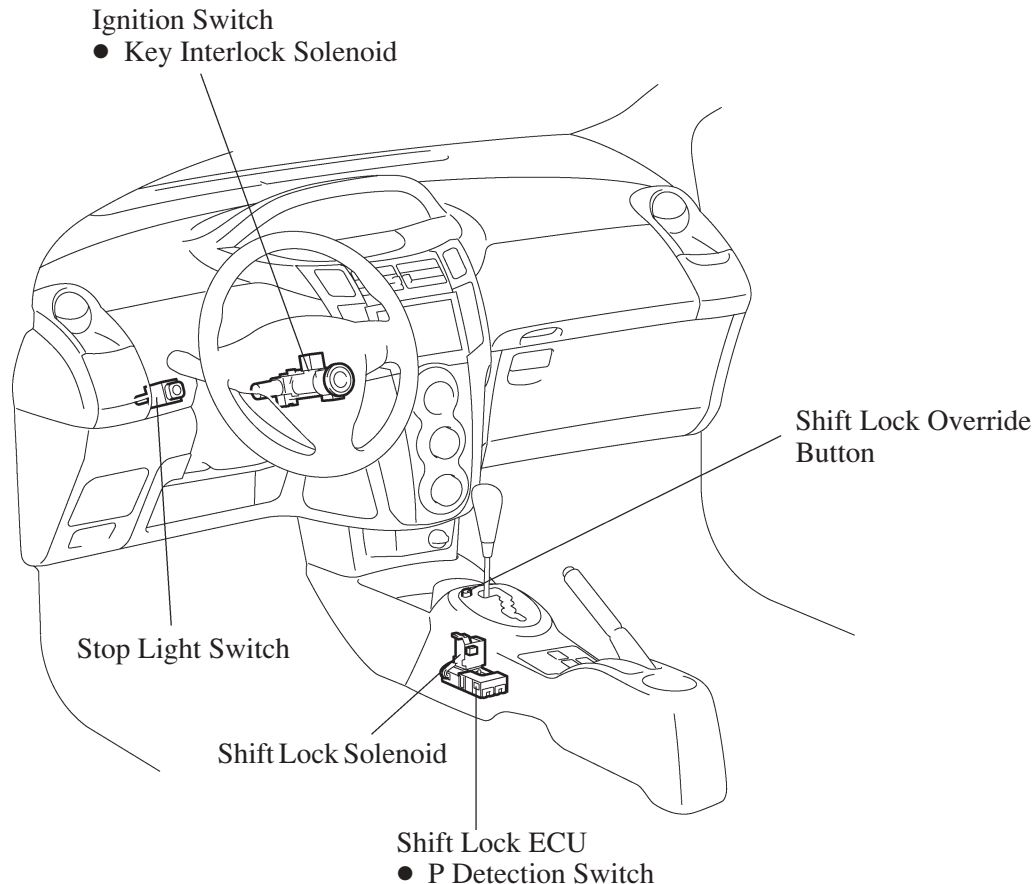



## Key Interlock Solenoid

The activation of the key interlock solenoid that is mounted on the upper column bracket moves the lock pin to restrict the movement of the key cylinder. Therefore, if the shift lever is shifted to any position other than “P”, the ignition key cannot be moved from the “ACC” to the “LOCK” position.

Key Interlock Solenoid

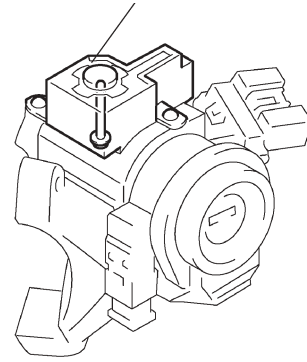

00SCH62Y

## System Operation

- The shift lock ECU uses the P detection switch to detect the shift lever position, and receives input signals from the stop light switch and ignition switch. Upon receiving these signals, the shift lock ECU turns ON the key interlock solenoid and the shift lock solenoid in order to release the key interlock and shift lock.
- A shift lock override button, which manually overrides the shift lock mechanism, is used.

### ► System Diagram ◀

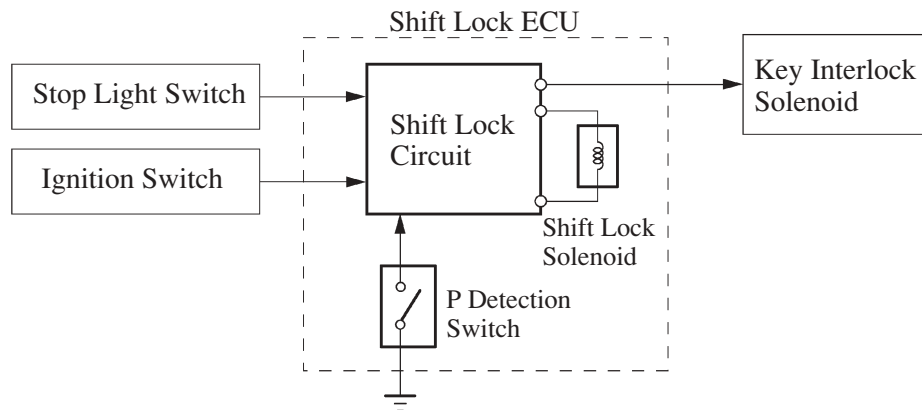

232CH94